

ENTREMAT^{IC}

Industrial HVLS Fan User's Manual

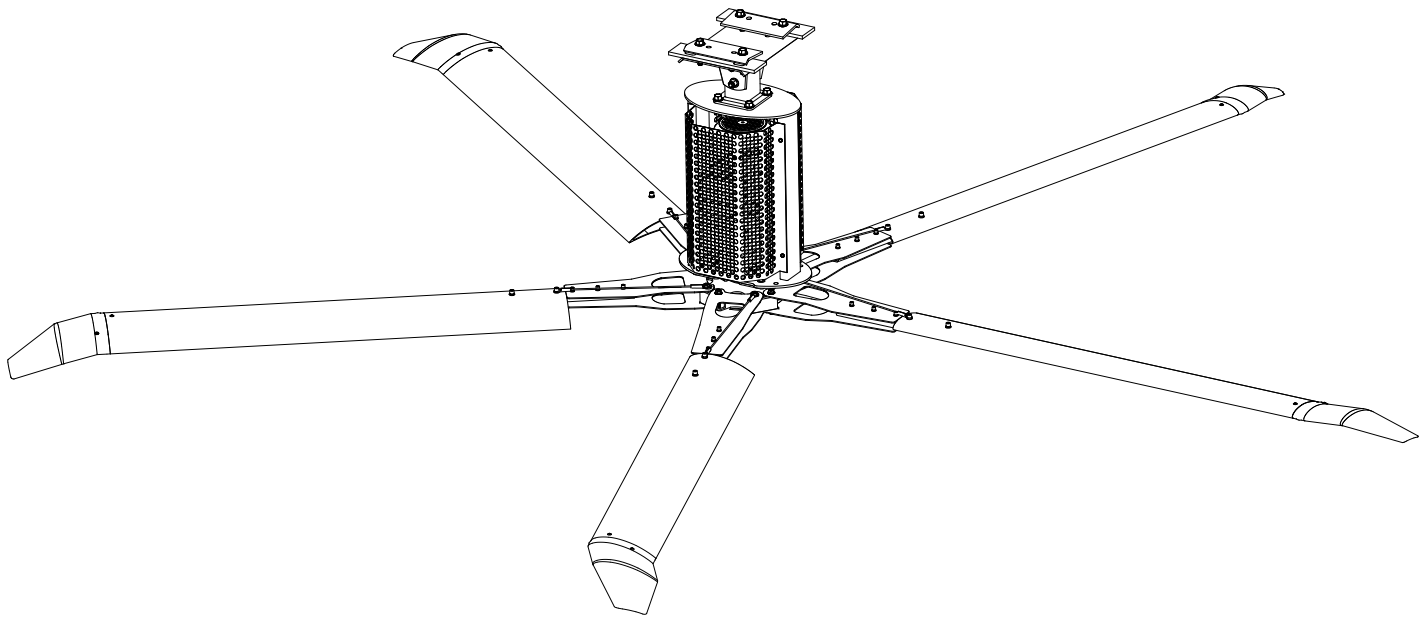

This manual applies to fans
manufactured beginning
February 2016.



▲ WARNING

Do not install, operate or service this product unless you have read and understand the Safety Practices, Warnings, and Installation and Operating Instructions contained in this User's Manual. Failure to do so could result in death or serious injury.

User's Manual

Installation, Operations,
Maintenance and Parts

Part No. 6015653G

TABLE OF CONTENTS

Introduction.....	2	Operating Instructions	19
Safety Signal Words	2	Planned Maintenance.....	26
Safety Practices.....	3	Troubleshooting Guide	27
Owner’s Responsibilities	4	VFD Fault Codes	29
Hardware	5	Fire Control System Option	30
Fan Kit.....	6	Wiring Details	33
Installation Considerations	7	Parts List.....	39
Installation	9	Warranty Information	51
Components and Specifications	18	Distributor Information	52

INTRODUCTION

Welcome and thank you for choosing this industrial fan from 4Front Engineered Solutions®

This User’s Manual contains information that you need to safely install, operate and maintain the fan. It also contains a complete parts list and information about ordering replacement parts. Please keep and read this User’s Manual before using your new fan.

SAFETY SIGNAL WORDS

You may find safety signal words such as DANGER, WARNING, CAUTION or NOTICE throughout this User’s Manual. Their use is explained below:



This is the safety alert symbol. It is used to alert you to potential personal injury hazards. Obey all safety messages that follow this symbol to avoid possible death or injury.

▲ DANGER

Indicates an imminently hazardous situation which, if not avoided, will result in death or serious injury.

▲ WARNING

Indicates a potentially hazardous situation which, if not avoided, could result in death or serious injury.

▲ CAUTION

Indicates a potentially hazardous situation which, if not avoided may result in minor or moderate injury.

NOTICE

Notice is used to address practices not related to personal injury.

SAFETY PRACTICES

⚠ WARNING

READ AND SAVE THESE INSTRUCTIONS.

READ THESE SAFETY PRACTICES BEFORE INSTALLING, OPERATING OR SERVICING THE FAN. Failure to follow these safety practices could result in death or serious injury.

READ AND FOLLOW THE OPERATING INSTRUCTIONS IN THIS MANUAL BEFORE OPERATING THE FAN. If you do not understand the instructions, ask your supervisor to teach you how to use the fan.

To reduce the risk of personal injury, do not bend the blade brackets when installing the brackets, balancing the blades or cleaning the fan. Do not insert foreign objects in between rotating fan blades.

⚠ DANGER

To reduce the risk of fire, electric shock and injury to persons, HVLS fan motor assemblies must be installed with the blade assemblies that are marked on their cartons to indicate the suitability with this model. Other blade assemblies cannot be substituted.

Be certain to follow the instructions in this manual.

If you do not understand the instructions, ask your supervisor to explain them to you or call your authorized local distributor.

INSTALLATION AND OPERATION:

⚠ WARNING

Installation of the equipment must comply with local and national electrical codes and must be in accordance with ANSI/NFPA 70-1999.

Do not use this industrial fan until you have received proper training. Improper use could result in property damage, bodily injury and/or death. Read and follow the complete OPERATING INSTRUCTIONS on pages 19-25 before use. If you do not understand the instructions, ask your supervisor to explain them to you or call your local distributor.

DO NOT USE THE FAN IF IT APPEARS DAMAGED OR DOES NOT OPERATE PROPERLY. Inform your supervisor immediately.

Do not operate the fan until all personnel, building structure and moveable equipment are clear of all moving parts. Install guards as required.

To reduce the risk of electric shock, do not expose to water or rain.

Support directly from building structure. Do not install the fan unit onto structure of insufficient strength. Consult a professional engineer or registered architect. Improper installation of the fan could result in death or serious injury.

⚠ CAUTION

To reduce the risk of injury to persons, install fan so that the blade is at least 3.05m (10') above the floor.

MAINTENANCE AND SERVICE:

⚠ DANGER

Before service, inspection, or cleaning make certain that the power is disconnected and properly locked out.

If the fan does not operate properly using the procedures in this manual, **BE CERTAIN TO REMOVE POWER FROM THE UNIT AND LOCK-OUT THE DISCONNECT ON THE POWER CIRCUIT.** Call your local distributor for service.

Keep your body clear of moving parts at all times.

All electrical troubleshooting and repair must be done by a qualified technician and meet all applicable codes.

If it is necessary to make troubleshooting checks inside the VFD box with the power on, **USE EXTREME CAUTION.** Do not place fingers or un-insulated tools inside the enclosure. Touching wires or other parts inside the enclosure could result in electrical shock, death or serious injury.

⚠ WARNING

Variable Frequency Drive (VFD) fan controllers contain high voltage capacitors. Before working on the fan controller, ensure isolation of the main voltage supply and verify voltage has bled off prior to beginning work. Failure to do so may result in death or serious injury.

If you have problems or questions, contact your local distributor for assistance.

OWNER'S RESPONSIBILITIES

The owner's responsibilities include the following:

The owner should recognize the inherent danger of the interface between the industrial fan and shop worker. The owner should, therefore, train and instruct operators in the safe use of the industrial fan.

Nameplates, cautions, instructions and posted warnings shall not be obscured from the view of operating or maintenance personnel for whom such warnings are intended. Warnings which are worn or non-legible should be replaced.

Manufacturer's recommended periodic maintenance and inspection procedures in effect at date of shipment shall be followed, and written records of the performance of these procedures should be kept.

Industrial fans that are structurally damaged or have experienced impacts from external sources, shall be removed from service, inspected by the manufacturer's authorized representative, and repaired as needed before being placed back in service.

The owner shall see that all nameplates and caution and instruction markings or labels are in place and that the appropriate operating and maintenance manuals are provided to users.

Modifications or alterations of industrial fans shall be made only with written permission of the original manufacturer.

HARDWARE

Mount – Building

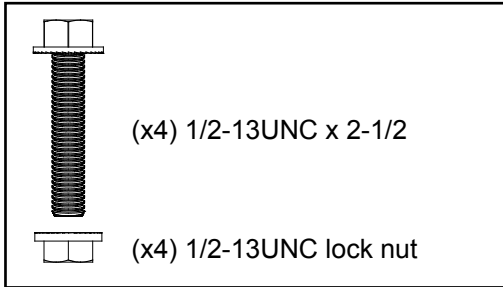

Mount – Assembly

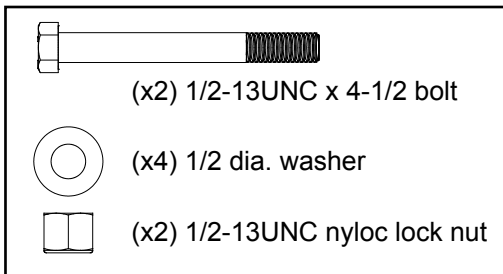

Mount – Motor frame

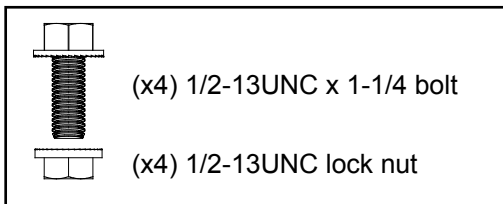

Mount – Blade

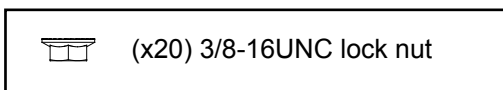

Mount – Fan cover

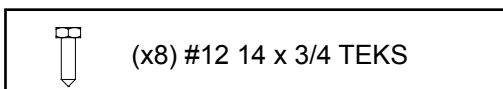

Guy wire assembly

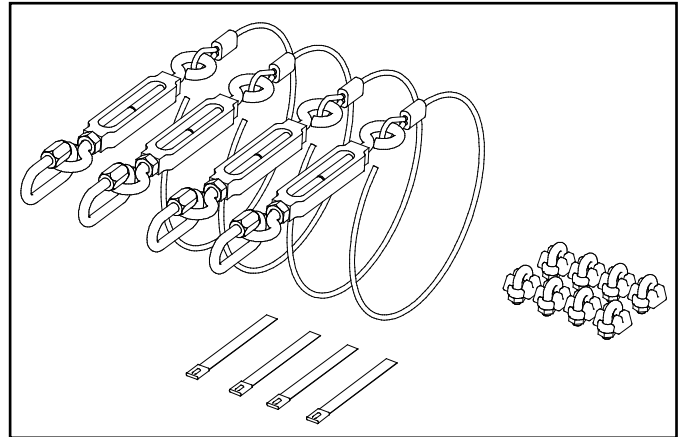

Safety cable

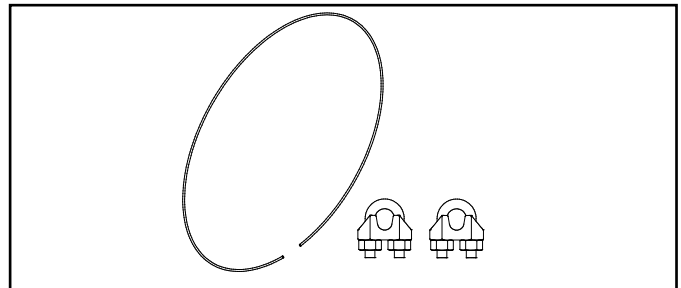

Identification labels

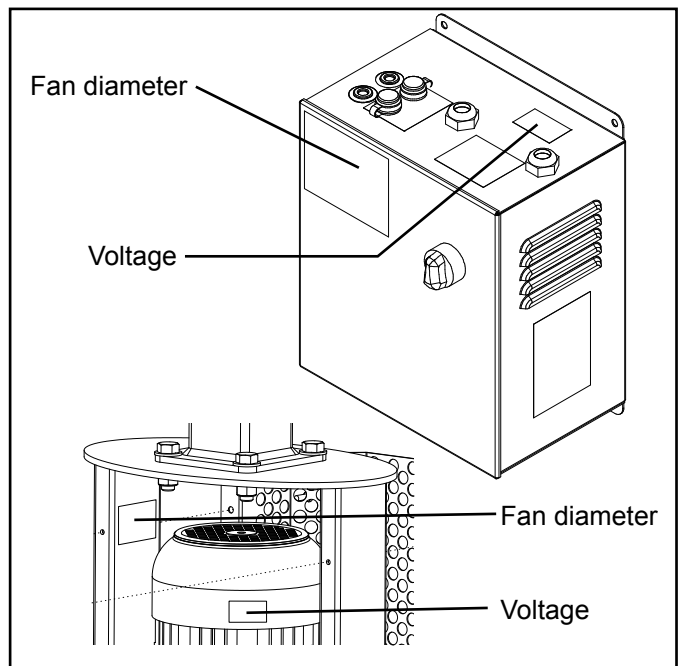

Fastener torque requirements

Description	Torque	Wrench size
1/2 dia mount hardware	44-48 ft-lbs.	3/4 hex
3/8 dia blade mount hardware	24-28 ft-lbs.	9/16 hex
3/8 dia safety bracket hardware	24-28 ft-lbs.	9/16 hex
1-3/4 dia hub retaining nut	125 ft-lbs.	1-3/4 hex
1/2 dia hub cover fastener	44-48 ft-lbs.	3/4 hex
Cable clamp, guy wire	Secure tight	1/4 nut driver
Cable clamp, safety cable	Secure tight	5/16 nut driver
Motor cover fastener	Secure tight	5/16 nut driver

NOTE:

Additional spare hardware is provided as a courtesy.

FAN KIT

PACKING KIT (Standard)

1. Blade Box – 5 each
2. Fan Motor Box
 - a. Motor/gearbox assembly with covers.
 - b. Remote control panel with junction box.
 - c. Category 5e cable set – 100 ft (one blue, one gray)
 - d. Mounting hardware. See page 5.
 - e. VFD box.

PACKING KIT — iFAN (Networked)

See iFAN user's manual 6015948.

REQUIRED TOOLS

- Wrenches: 7/16, 9/16, 3/4 (x2), 1/2
- Sockets: 7/16, 1/2, 9/16, 3/4, 1-3/4
- Nut drivers: 1/4, 5/16
- Torque wrench: 15-60 Ft-lbs (for use with sockets)
- Wire strippers
- 1/4" cable cutter
- Tape measure
- Spirit level, short
- Gloves
- **For laminated wood beam installs, a drill and 1/2" dia. drill bit are required.**

NOTICE

PRIOR TO FAN INSTALLATION:

1. Ensure that the supplied voltage matches the fan voltage. A label containing voltage information specific to the individual fan is located on top of the VFD box.
2. Ensure blade length matches fan model size. See Fig. 1. Consult fan model designation located on the side of the fan powerhead frame.
3. Ensure all mounting hardware shown on page 5 is present.

FOR OPTIONAL IFAN NETWORK FANS ONLY

Ensure fan number matches network layout. Consult the round, network ID number label on shipping box.

NATIONAL FIRE PROTECTION ASSOCIATION STANDARD

In accordance with NFPA 13 Standard from the National Fire Prevention Association as referenced in sections 12.1.4 and 11.1.7: High Volume Low Speed (HVLS) Fans: The installation of HVLS fans in buildings equipped with sprinklers, including ESFR sprinklers, shall comply with the following:

- The maximum fan diameter shall be 24 feet (7.3 m).
- The fan shall be approximately centered between four adjacent sprinklers.
- The vertical clearance from the fan to sprinkler deflector shall be a minimum of 3 feet (0.9 m).
- All fans shall be interlocked to shut down immediately upon receiving a water flow signal from the alarm system in accordance with the requirements of NFPA 72- National Fire Alarm and Signaling Code.

INSTALLATION CONSIDERATIONS

Fig. 1

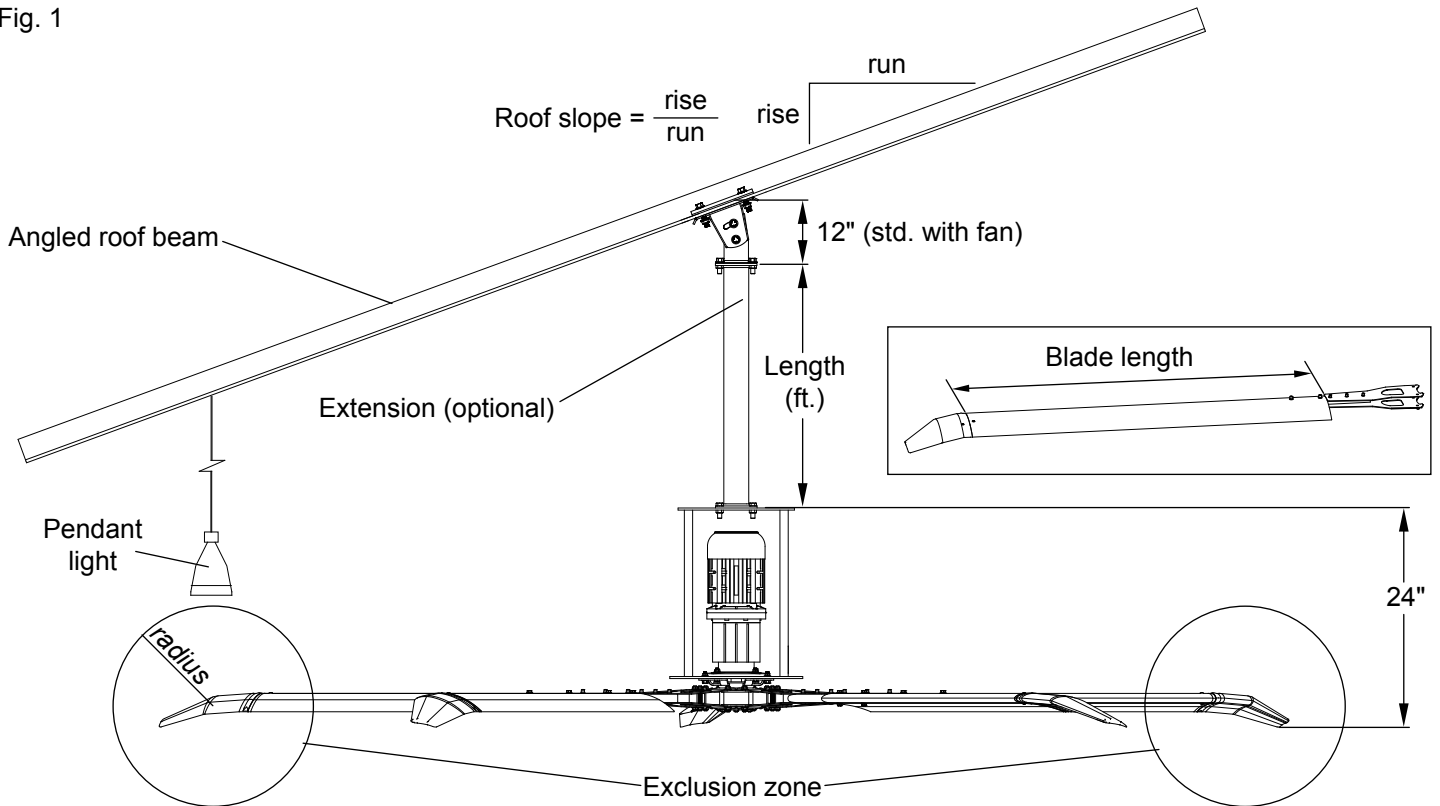

ROOF SLOPE

Roof Slope*	2/12	3/12	4/12	Hanging Weight (Lb)	Maximum Torque (Ft. Lb)	Exclusion Zone Radius (In.)	Blade length (In.)
Roof Angle*	9.5°	14.0°	18.4°				
Fan Diameter (Ft)	Extension Length (Ft.)						
6	N/A	N/A	N/A	140	300	15	25.0
8	N/A	N/A	N/A	160	300	15	27.5
10	N/A	1	2	181	300	15	39.5
12	N/A	1	2	190	300	15	51.5
14	2	2	3	194	300	15	63.5
16	2	3	4	208	300	30	75.5
18	3	4	4	203	300	30	87.5
20	3	4	5	220	300	30	99.5
24	4	5	6	258	300	30	123.5

*Consult your local distributor for assistance with fan placement and extension selection.

NOTE:

For roof angles in excess of 20°, consult factory. The extension lengths shown are minimum recommendations only, based solely of roof pitch and fan diameter. Other considerations must be evaluated when determining extension requirements, such as placement of lights, sprinkler systems, HVAC systems, etc. In addition, OSHA requirements state that fan blades must be a minimum of 10' above the floor.

INSTALLATION CONSIDERATIONS, continued

BUILDING STRUCTURE

For open structure roof designs, the fan should only be hung from either I-beam or angle iron. Do not hang from purlins, joists or truss structure.

For solid beam or laminated wood beam mounting, use the laminated wood beam mounting kit available from 4Front.

Consult a professional engineer or registered architect for specific mounting concerns.

Ensure fan blade clearance meets the requirements. See Fig. 1.

PLACEMENT AND SPACING

Consult your local distributor to help you plan the most efficient installation of your fans.

Ensure fan placement is such that the fans blades are a minimum of 10' from any manned working surface (floor or mezzanine)

Ensure fan blade does not extend into exclusion zone. Extensions are available if required. See Fig. 1.

Avoid mounting fans directly under lights or skylights to avoid visual strobing affect.

NOTE:

If the fan is part of a networked system, ensure placement is in accordance with the building layout. Fan network identification number is located on the front panel of the VFD box.

NOTE:

Be certain to comply with all local and national codes during installation.

NOTICE

For fans that will be subjected to high cross winds (open bay doors or air conditioning diffuser ducts) the fan must be at least one fan diameter (as measured from the end of the winglet) from open bays or A/C ducts mounted below the blade plane or there must be at least two fan diameters (as measured from the end of the winglet) for A/C ducts mounted at or above the blade plane.

Fig. 2

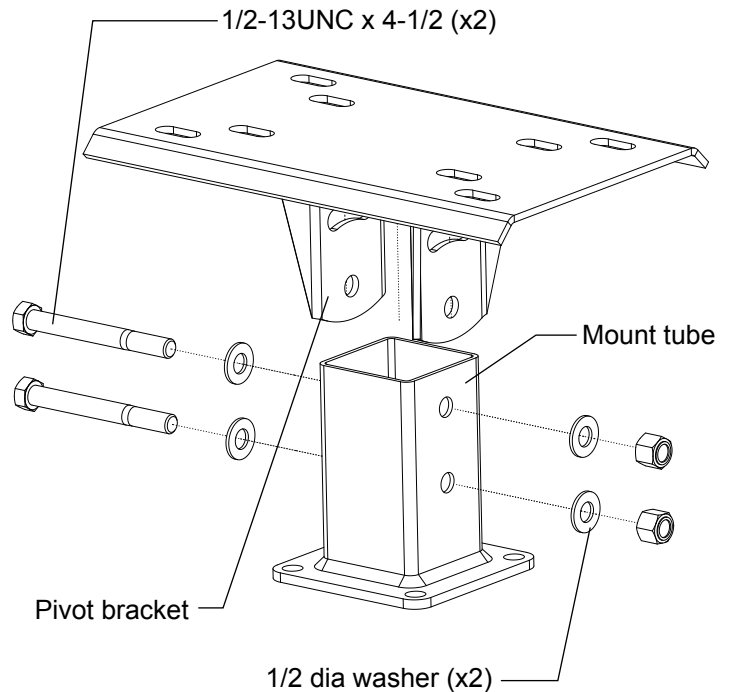

INSTALLATION

▲DANGER

Before installation, make certain that the power is disconnected and properly locked out.

FAN MOUNT ASSEMBLY

1. Fasten pivot brackets to the extension tube with ears outboard. Leave the 1/2" dia. x 4-1/2" bolts and nylock nuts finger tight. See Fig. 2.

INSTALL FAN MOUNT

STANDARD I-BEAM

1. Locate fan mount assembly on bottom of building support beam. Align mount assembly so that it is centered and square to the beam. Orient mount such that the pivoting axis is aligned with the building slope if required. See Fig. 3.
2. Install clamps. For thick flange I-beams add shims as required. Fasten using the supplied 1/2" dia x 2-1/2" screws, lock nuts and washers. Torque to 44-48 ft-lbs. See Fig. 4.

Fig. 3

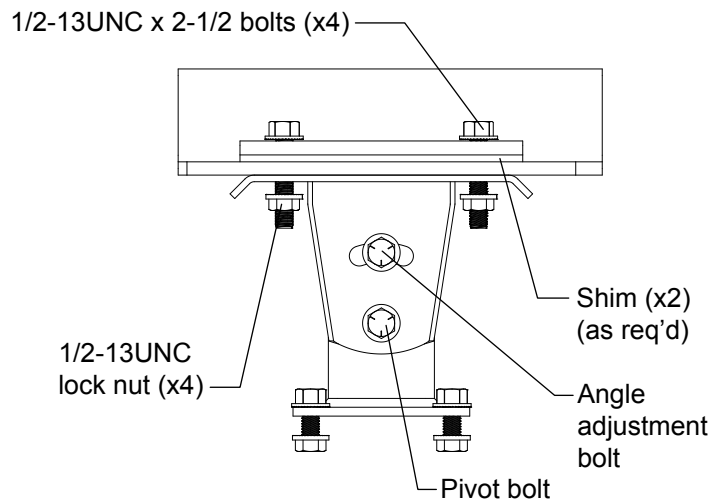
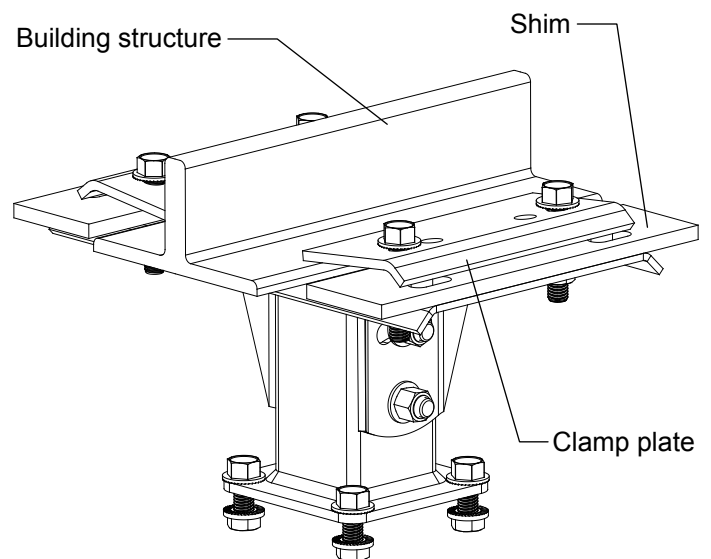

Fig. 4



INSTALLATION, continued

NOTICE

If building support beam is not level, ensure proper fan clearance using the mounting information shown on page 7 or add mounting extensions as required to ensure clearance. See Fig. 1.

LAMINATED WOOD BEAM MOUNTING — (OPTIONAL KIT 6014915)

1. Attach laminated wood beam brackets to the wooden beam using a minimum of four 1/2" dia. grade 5 thru bolts and self-locking nuts (not supplied). Ensure brackets are square to the bottom of the beam.
2. Attach mount assembly to the laminated wood beam brackets using the supplied 1/2" dia x 2-1/2" screws, nylock lock nuts and washers. Torque to 44-48 ft-lbs. See Fig. 5.

TRUSS MOUNT

NOTE:

Do not span gaps longer than 72".

To span two trusses or purlins with a gap of 72" or less, span the gap using two 12 gage steel 1-5/8" x 1-5/8" strut channel. This will require additional hardware not included with the fan. Do not use strut channel clamps for any connections when mounting the fan.

Consult a professional engineer or registered architect for specific mounting concerns.

Fig. 5

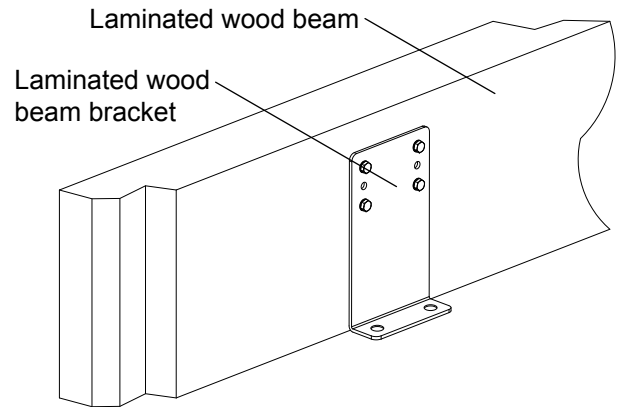

Fig. 6

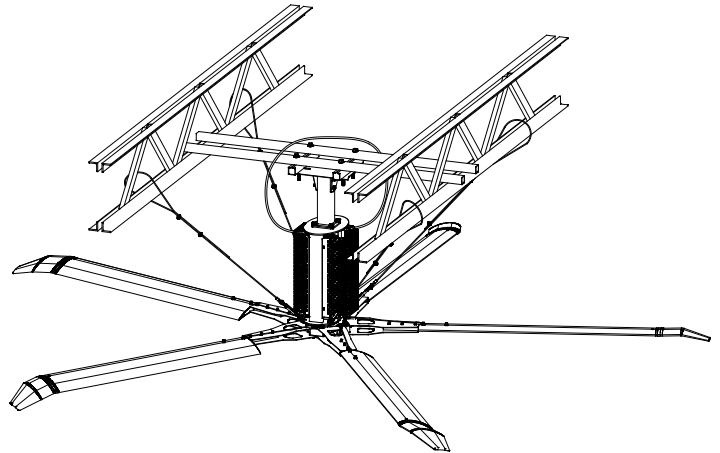
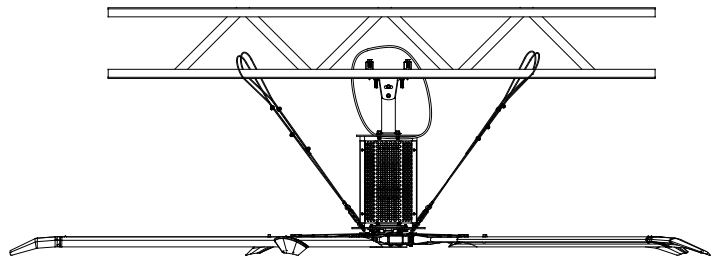

Fig. 7



INSTALLATION, continued

INSTALL POWERHEAD (MOTOR/GEARBOX ASSY)

1. Using a powered lift, orient the powerhead with the blade hub down. Block motor as required for installation using the bottom of the frame assembly. Do not support using the hub or hub cap.

NOTE:

Fan powerhead may be oriented as required for aesthetics or commonality.

2. Raise the powerhead up until it contacts the bottom of the fan mount assembly. See Fig. 8.
3. Immediately attach safety cable. See Fig. 10.
 - a. Slide two of the supplied 1/4" dia cable clamps over each end of the cable spaced 6" apart.
 - b. Slide the ends through the cable clamps.
 - c. Make sure that the cable goes through the motor frame. See Fig. 10.
 - e. Securely tighten the clamp fasteners. Make sure the u-bolts are over the free ends of the cable.
 - f. Ensure assembly does not interfere with fan motor housing.
4. Fasten the powerhead to the mount assembly using the supplied 1/2" dia x 1-1/4" bolts, self-locking nuts and washers. Torque to 44-48 ft-lbs. See Fig. 9.

NOTICE

If a mounting extension has been used, it may be necessary to obtain a longer cable from a local supplier.

Fig. 8

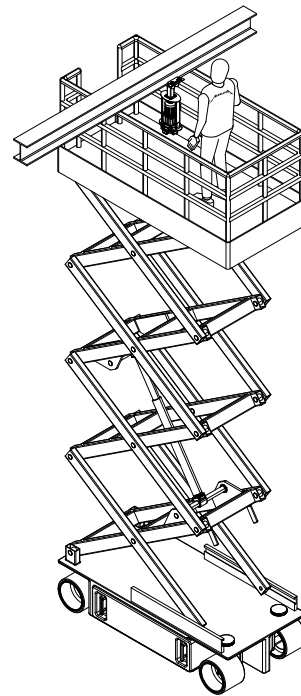

Fig. 9

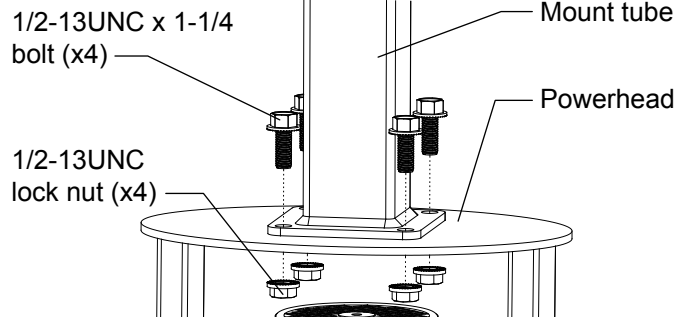
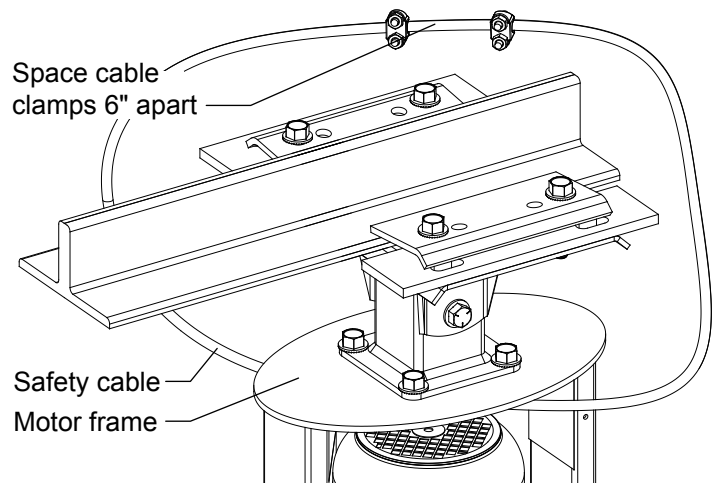

Fig. 10



INSTALLATION, continued

INSTALL GUY WIRES

Guy wires are designed to constrain lateral movement of the fan in operation. This movement may be due to impacts on the fan or winds impinging on the blades that would cause the fan to sway.

NOTICE

Failure to attach guy wires may result in loss of warranty.

⚠ WARNING

If a mounting extension has been used, ensure that the longer guy wires accompanying the extension are used. Ensure that the angle formed by the guy wire with the roof structure is less than 45°. See Fig. 12. Avoid any sharp edges or corners to reduce fatiguing and fraying of the guy wires. Failure to attach guy wires may result in severe injury or death.

1. Adjust turnbuckles to their longest position.
2. Attach the quick link with attached turnbuckle to the fan as shown. Repeat for all four quick links.
3. Attach one end of the guy wire to the building structure. Ensure the structure has sufficient strength to withstand the wire tension. Repeat for all four guy wires.
 - a. Slide two of the supplied 1/8" dia cable clamps over one end of the wire.
 - b. Feed that end of the wire through the building structure and back through the clamp fasteners.
 - c. Securely tighten the clamp fasteners so that it cannot slip. Make sure the u-bolts are over the free end of the cable.
4. Individually tighten the turn buckle on each cable until each cable is taut and the powerhead unit hangs plumb. Use a spirit level to verify powerhead unit hangs plumb.
5. Tighten pivot and angle adjustment bolts on fan mount. Torque to 44-48 ft-lbs. See Fig. 3.

Fig. 11

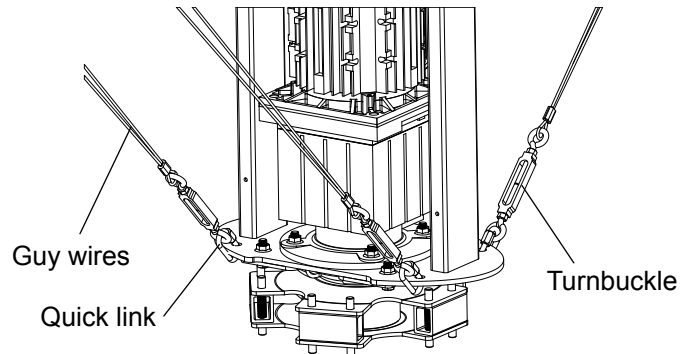
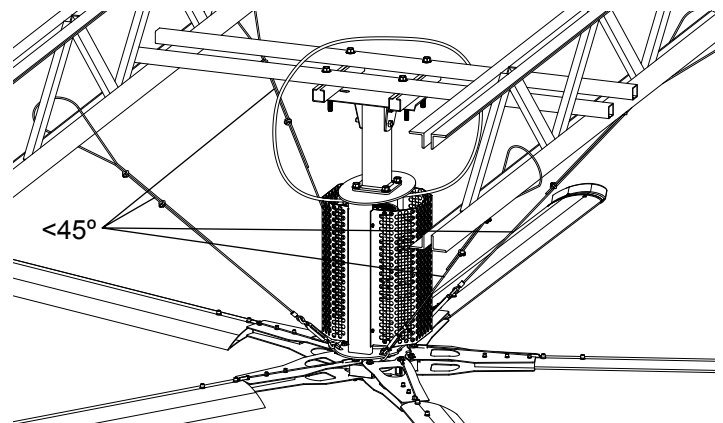

Fig. 12



INSTALLATION, continued

INSTALL BLADES

⚠ WARNING

To reduce the risk of personal injury, do not bend the blade brackets when installing the brackets or cleaning the fan. Do not insert foreign objects in between rotating fan blades.

NOTE:

Blade assemblies come pre-assembled from the factory. Do not attempt to disassemble.

1. The hub assembly has special blade retention lock nuts pre-assembled to it. Remove them now and use them to mount the blade assemblies in the steps below. Use only the factory supplied lock nuts provided for blade mounting.
2. With the blade oriented such that the blade retention lanyard is on top and positioned so that the lanyard ends are aligned toward one another, support the blade assembly from below, orient and guide the assembly onto the top attachment studs on the hub assembly. Spread the strut arms slightly onto the upper studs as shown. Angle the blade upward as needed to slide blade onto studs. See Fig. 13.
3. Still supporting the blade assembly, rotate the blade assembly down as shown and allow the bottom blade strut to ride up and over the bottom attachment studs on the hub assembly. See Fig. 14.

NOTICE

Do not lean on blade. Damage to strut may occur.

4. Install blade retention lock nuts. Ensure blade lanyard is assembled onto trailing edge stud. Hand tighten nuts ensuring strut arms are firmly pressing against hub. Torque blade retention nuts to 24-28 ft-lbs. See Fig. 15.
5. Repeat for each blade assembly.

GEARBOX VENT PLUG

1. Locate ventilation plug on gearbox. See Fig. 16.
2. Pull and remove plastic shipping brace and discard.

Fig. 13

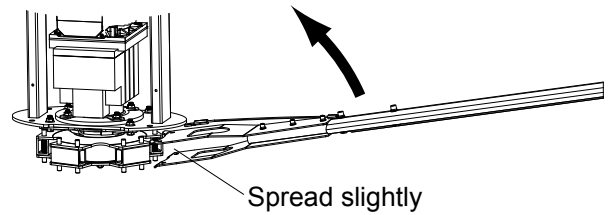

Fig. 14

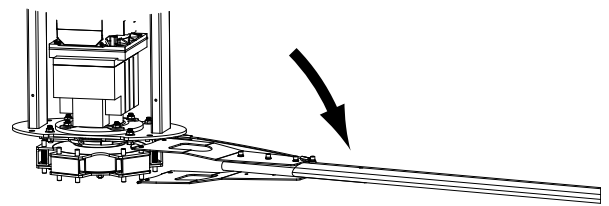

Fig. 15

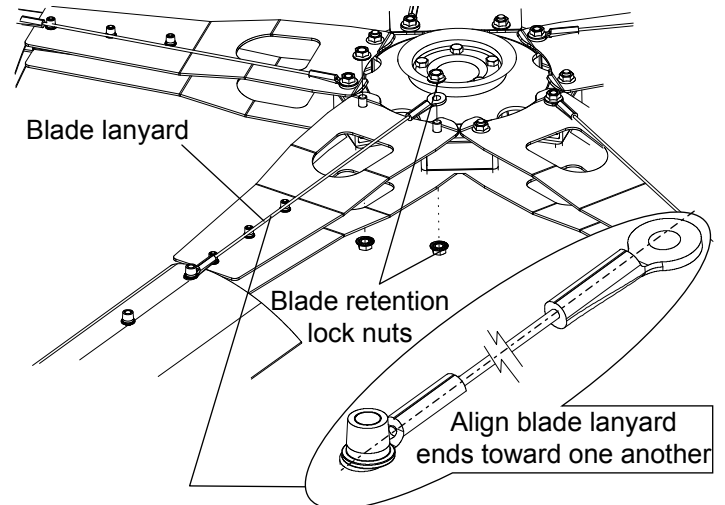
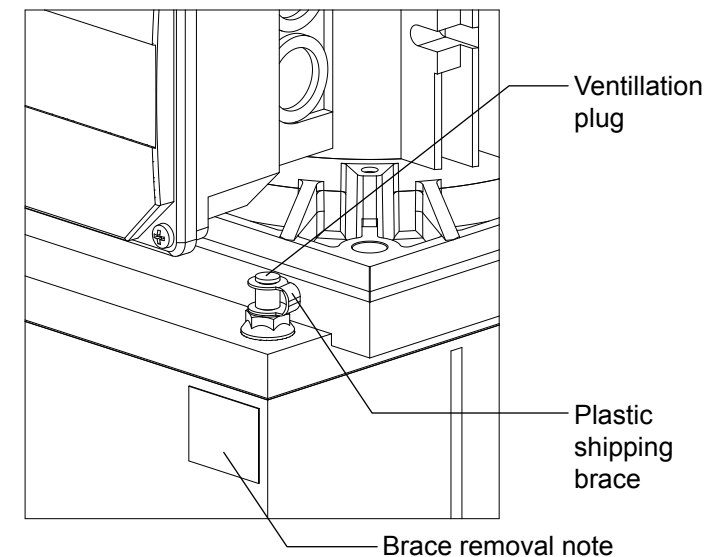

Fig. 16



INSTALLATION, continued

3. Remove orange brace removal note and discard.

Fig. 17

INSTALL MOTOR COVER

1. Ensure that the motor SO cable has been routed to VFD box and is secured. See electrical installation instructions.
2. Locate each motor cover and install the cover fasteners. Do not overtighten. See Fig. 17.

VERIFY CLEARANCE AND CABLE TENSION

1. Rotate fan by hand and observe clearance of each blade with closest obstruction. If necessary, reposition fan. Blade tips droop when not in operation and rise when in operation. Reference chart on page 7 for min. clearance.
2. Verify guy wire tension by attempting to move powerhead in any horizontal direction. If movement is detected, re-tension guy wires.
3. Lock the individual turnbuckles using the stop nut on each and secure it with the turnbuckle strap. See Fig. 18.

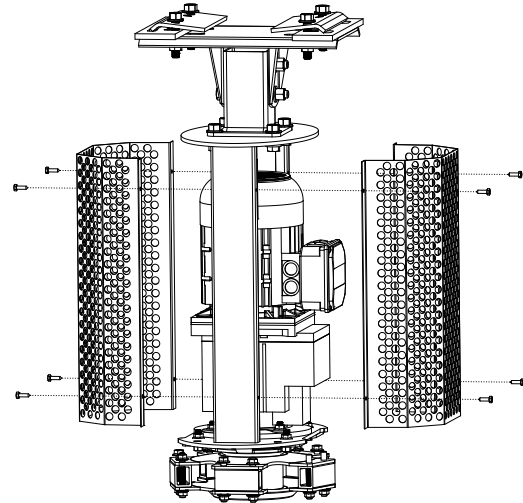

ELECTRICAL INSTALLATION

▲ DANGER

Before doing any electrical work, make certain the power is disconnected and properly locked or tagged off. Failure to do so may result in death or serious injury. All electrical troubleshooting and repair must be done by a qualified technician and meet all applicable codes. Do not route control wiring for any other device through the control box. Ensure that the voltage and phase of the incoming power agrees with the label located on top of the VFD box and fan. Be certain power is off when wiring to the control box. Failure to do so could result in electrical shock, death or serious injury.

Fig. 18

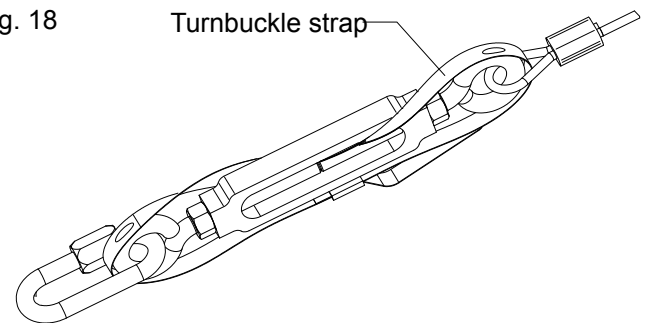

STANDARD UNITS

NOTE:

Reference wiring diagrams on pages 33-37 for all field connections.

NOTICE

Do not over-torque mounting screws. Damage to display screen may occur if mounting screws are over-torqued. It is the installer's responsibility to torque properly.

INSTALLATION, continued

INSTALL VFD BOX

⚠ WARNING

The VFD box must be installed outside and a safe distance from the blade diameter for service purposes.

NOTICE

Verify voltage and phase before mounting. Ensure voltage shown on VFD box is correct.

2. Mount VFD box outside the fan blade arc. Orient box such that front panel is accessible and visible with the connectors on top of the panel.
3. Route the fan S.O. cable from the fan to the VFD box. Ensure the cable is supported throughout its routing.
4. Route supply power from the building source to the VFD box.
5. Wire VFD box in accordance with electrical schematics located on pages 33-37.
6. Attach remote signal (blue) and diagnostic (gray) CAT5e cables.

INSTALL REMOTE CONTROL

1. Mount touch screen remote to factory supplied junction box inside building 60" above the floor as close to the fan assembly as practical. Direct line of sight is preferred. See Fig 19.

NOTE:

Blue CAT5e cable has terminated ferrules at the remote end. PROTECT these ferrules during cable routing.

2. Route the remote signal (blue) cable (6015651) and the diagnostic (gray) cable (6011643) from the top of the VFD box, through the hole in the factory supplied junction box and wire the 4 leads of the remote signal (blue) cable to the orange connector of the touch screen remote control. Neatly coil approximately 6" of the diagnostic (gray) cable in the junction box and secure. Excess blue and gray cable length should be neatly coiled and secured near VFD box.

Fig. 19

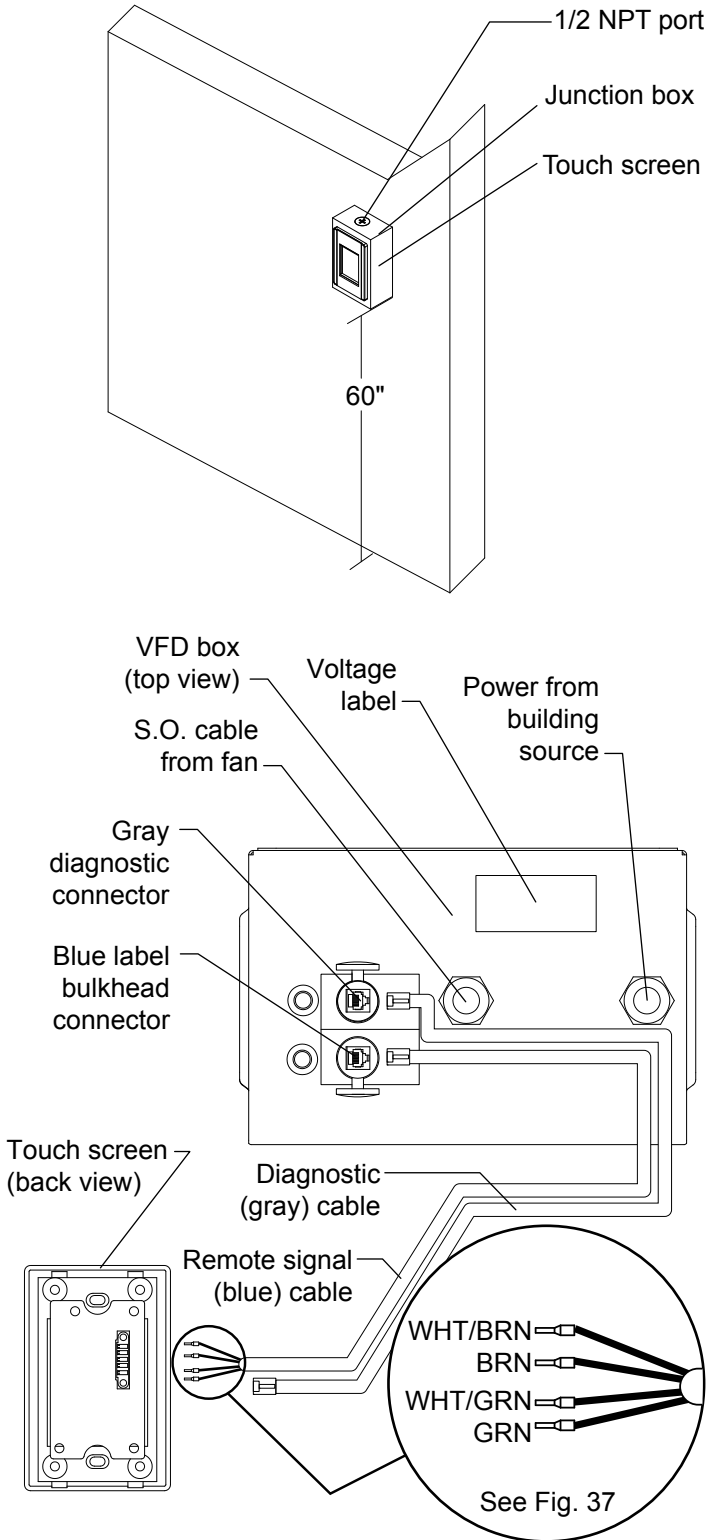

INSTALLATION, continued

3. Mount the touch screen to the junction box using the fasteners provided.

NOTE:

DO NOT over-torque the mounting screws. Damage to the display screen is possible. It is the installer's responsibility to torque properly.

NOTE:

For cable runs exceeding 1000', consult factory.

VERIFY OPERATION — STANDARD INSTALLATION

Once installation is complete, the initial view of the touchscreen control will prompt the installer to set and confirm the fan size. Use the **UP/DOWN** arrows to select the size of the fan and press the **SET** button. Ensure selected size matches the size specified on the label on the front of the VFD box. If it matches select the **YES** button on the following confirmation screen, if it differs, select the **NO** button and try again. See Fig. 20.

Operate the industrial fan following the operating instructions beginning on page 19. Check for proper rotation direction, stability and noise level.

Train authorized personnel how to use the industrial fan using the operating procedures located on pages 19-25 in this manual.

Fig. 20

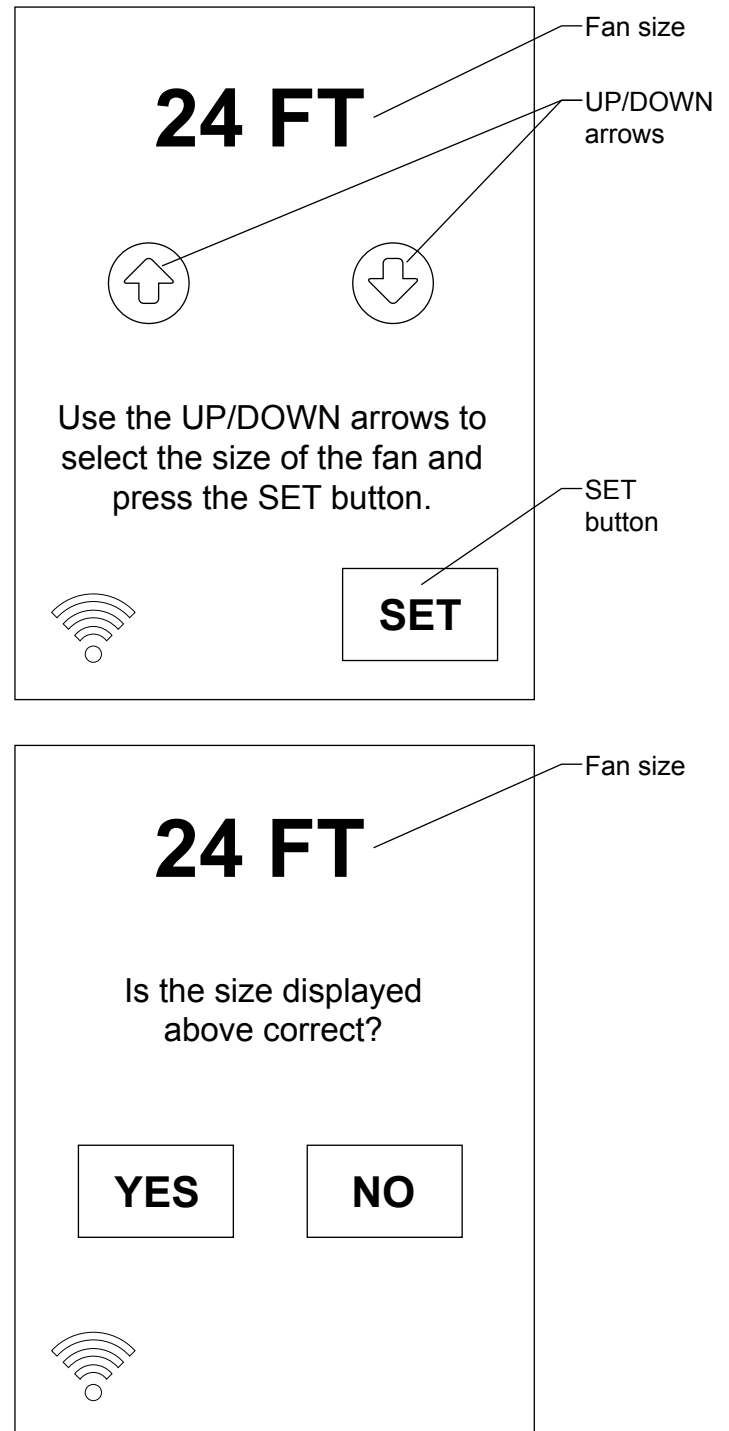

TEMPERATURE CONTROL — OPTIONAL

- 1. Mount temperature control unit to the factory supplied junction box inside building 60" above the floor and within 1000' of the fan touch screen remote. See Fig. 19 and wiring details on page 36.

NOTE:
FOR OPTIONAL NETWORKED UNITS, SEE SEPARATE MANUAL 6015948.

Fig. 21

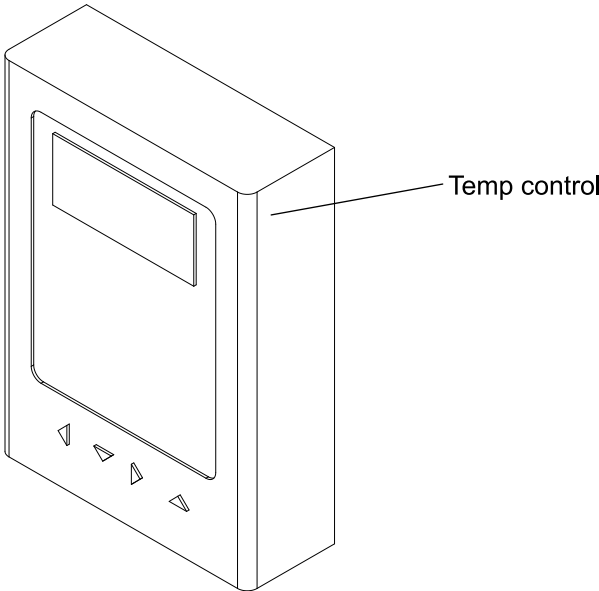

COMPONENTS AND SPECIFICATIONS

VFD BOX – NEMA 1, Solid State VFD (Variable Frequency Drive), 120VAC 1PH, 208-240VAC 1PH, 208–480 VAC, 3PH, line reactor (where required), Class CC fuses, UL and UL-C listed panel and components. Power disconnect.

MOTOR

NEMA standard T.E.F.C., 1-2 HP, continuous duty single or three phase

GEARBOX

Double helical gear reduced, sealed lubrication.

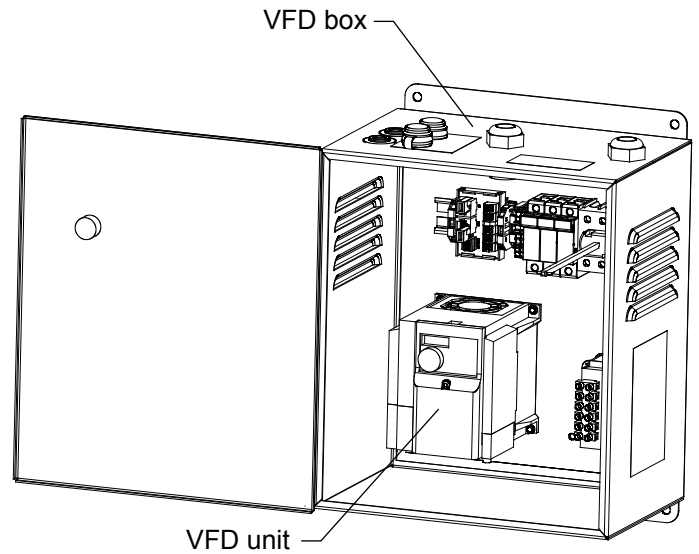
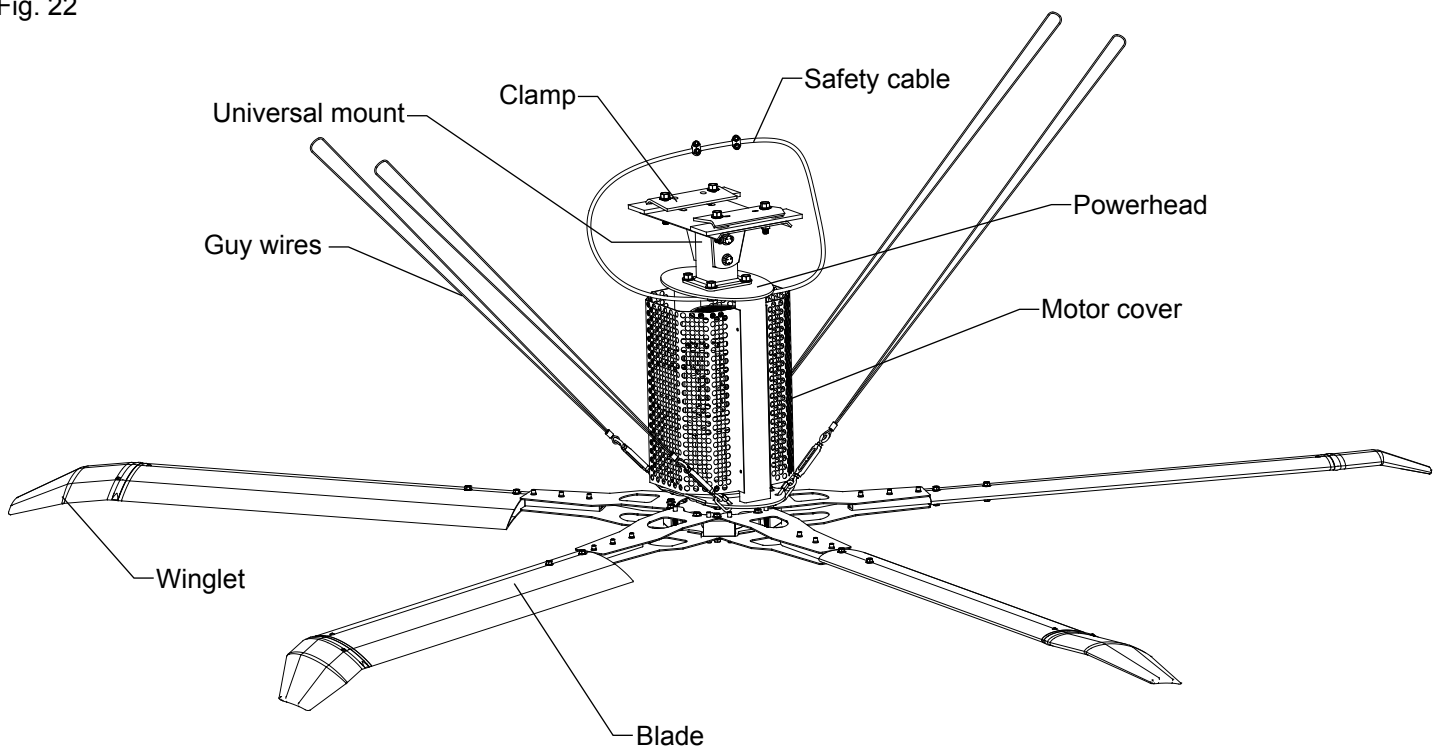

Fig. 22



OPERATING INSTRUCTIONS

Fig. 23

FAN CONTROL SCREEN

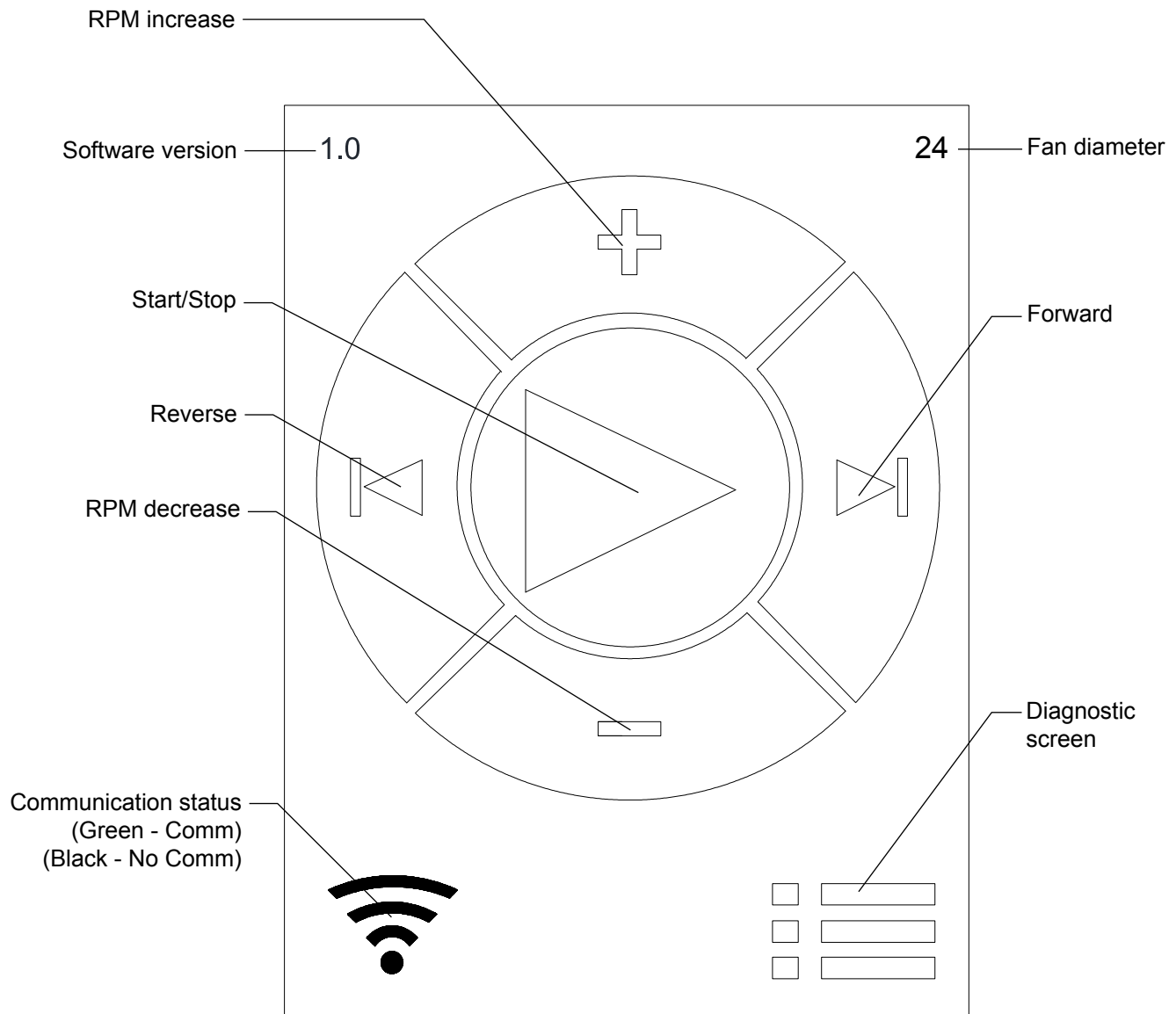

OPERATING INSTRUCTIONS, continued

⚠ WARNING

Before operating the industrial fan, read and follow the Safety Practices, Warnings and Operating Instructions in this manual. Use by untrained personnel could result in death or serious injury.

VERIFY PRIOR TO OPERATION

1. Voltage/phase.
2. Obstruction clearance.
3. Safety cables present and properly installed.
4. All fasteners are properly torqued.

STARTING THE FAN

Visually inspect the fan to ensure that there are no obstructions or personnel in the movement area.

LOGIN SCREEN

If the password has been enabled, you must log in before operating the fan.

NOTE:

Default password: 1111

NORMAL OPERATION

1. Verify normal communication — the communication status symbol in bottom lefthand corner will be green.
2. Set desired speed by pressing either **RPM increase** or **RPM decrease** until desired speed is displayed. Maximum speed is 10, minimum speed is 1. See Fig. 24.
3. Select fan direction by selecting either **Forward** or **Reverse**.

CHANGING DIRECTION

1. Select either **Forward** or **Reverse**. It is not necessary to stop the fan first.

DIAGNOSTIC SCREEN

The diagnostic screen (see Fig. 25) contains:

Service Provider information. Contact this provider for all fan service issues.

Fan Information:

- VFD serial number
- Fan power/voltage
- Motor Speed (x10)
- Motor Current (x10)
- Drive Status

Password Protection

Fig. 24

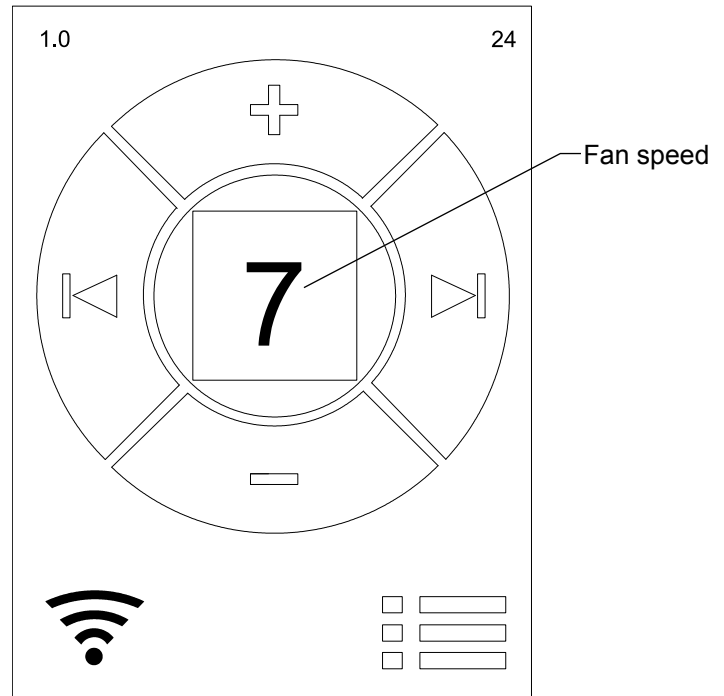
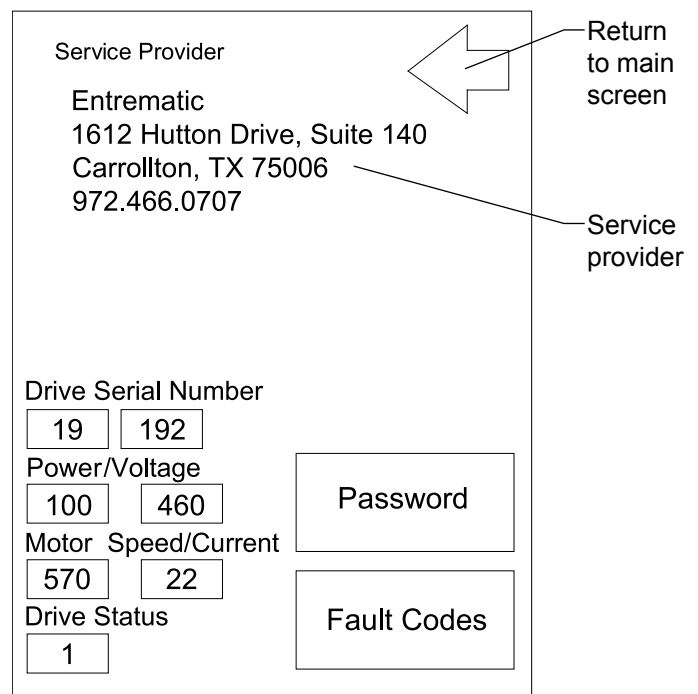

Fig. 25



OPERATING INSTRUCTIONS, continued

FAULT CODES

If a fault code alarm appears, select the **Fault Codes** button to display the fault codes,.

To navigate back to the main screen, Select the green return arrow.

The fault code screen will display the current fault code number and gives a description of each fault code. If the fan is currently under fault, the error code being displayed in the box under the green arrow will be displaying a number that caused the fault. Match the number with the error codes and remove the fault condition. Once the condition has been removed, pressing the reset button will reset the fan and allow operation again. Note that the error code will still be displayed in the box as it will continue to display the most recent fault. Finally, the green arrow in the upper right corner will navigate back to the diagnostic screen. See Fig. 26.

Fig. 26

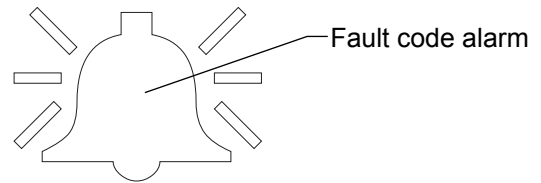
A screenshot of a digital display showing a list of error codes. At the top left, it says 'Drive Error Codes:'. Below this is a list of 20 error codes, each with a number and a description. On the right side of the screen, there is a large green arrow pointing left, a box containing the number '0', and a 'Reset' button. At the bottom right, there is a box containing the number '220'. A line points from the text 'Return to diagnostic screen' to the green arrow.

Drive Error Codes:

- 0 - No Alarm / Fan OK
- 16 - -Overcurrent during accel
- 17 - Overcurrent at speed
- 18 - Overcurrent during decel/stop
- 32 - Overvoltage during accel
- 33 - Overvoltage at speed
- 34 - Overvoltage during decel/stop
- 48 - Inverter overload
- 49 - Motor overload
- 64 - Heatsink Overheat
- 82 - Input phase loss
- 96 - Stall prevention
- 112 - Brake transistor alarm
- 128 - Ground fault overcurrent at start
- 129 - Output phase loss
- 144 - External thermal relay operation
- 145 - PTC thermistor operation
- 176 - Parameter storage device fault
- 177 - PU disconnection
- 178 - Retry count excess
- 192 / 245 - CPU fault
- 196 - Output current detection value exceeded
- 197 - Inrush current limit circuit fault
- 199 - Analog input fault
- 201 - Safety circuit fault

Return to diagnostic screen

OPERATING INSTRUCTIONS, continued

PASSWORD PROTECTION

The remote is capable of password protection to prevent unauthorized use.

1. Press the **diagnostic screen** button from the main screen.
2. Press the **Password** button on the diagnostic screen.

NOTE:

If the password has already been previously customized, enter it now. If not, the default password: 1111

On the password screen, the options are to enable the password, disable the password and change the password. By default, the password is not enabled.

To enable password, ensure the **Password On** box is checked.

To disable password, ensure the **Password On** box is unchecked.

UPDATING PASSWORD

1. Enter the desired password using the numeric keypad.
2. Press the **Update Password** button. See Fig. 27.

NOTE:

When the password is enabled, the unit will automatically log out after 2 minutes. To return to diagnostic screen, select green return arrow.

Fig. 27

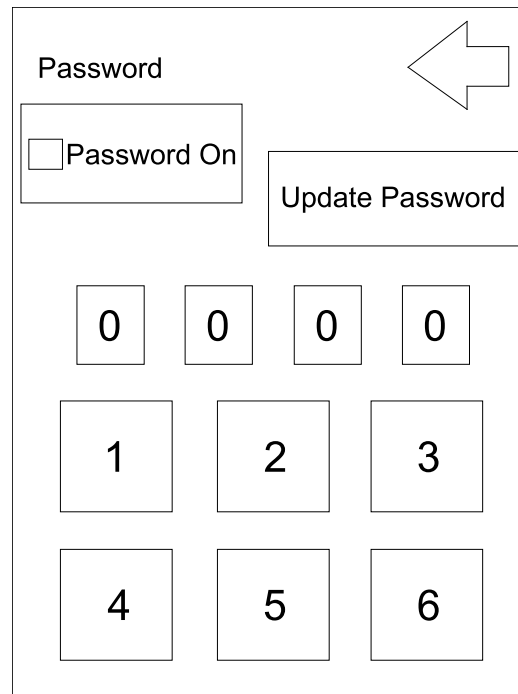

OPERATING INSTRUCTIONS, continued

TEMPERATURE CONTROL (OPTIONAL)

1. To enable the temperature control, cycle through START/STOP/TEMP control and check the box for temp control. When in temp control mode, a thermometer icon will appear on the display. See Fig. 28.
2. Enter a temperature at which to start the fan automatically. At this value the fan will start at speed 2.
3. Enter a value to increment the temperature for the next speed setting. This value is added to the start temperature from step 2 to set the temperature at which the fan will switch to speed 4, 6 and 8. For example: if 70° is entered for the start temperature and 3 is entered for the increment then the fan will start at speed 2 at 70° degrees and switch to speed 4 at 73° degrees and switch to speed 6 at 76° degrees and so on.
4. The fan will decrease in speed as the temperature decreases until it goes below the start point. Once the temperature is below the start temperature minus the increment temperature the fan will stop on its own.
5. To disable the temperature control, cycle through START/STOP/TEMP control and uncheck the box for temp control. Disabling temperature control will allow the fan to be controlled from the keypad on the main screen.
6. The user can select between fahrenheit and celsius units by checking or unchecking the celsius check box. See Fig. 29.

Fig. 28

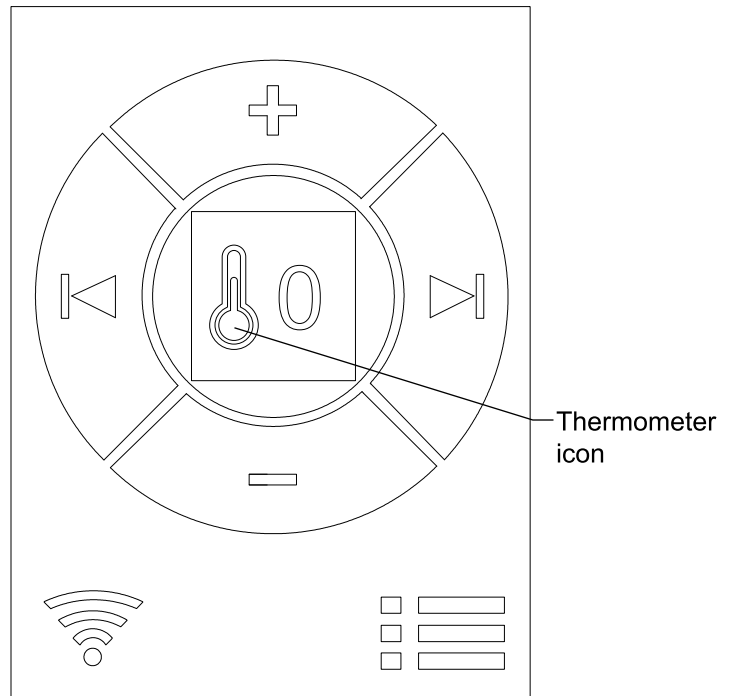

Thermometer icon

Fig. 29

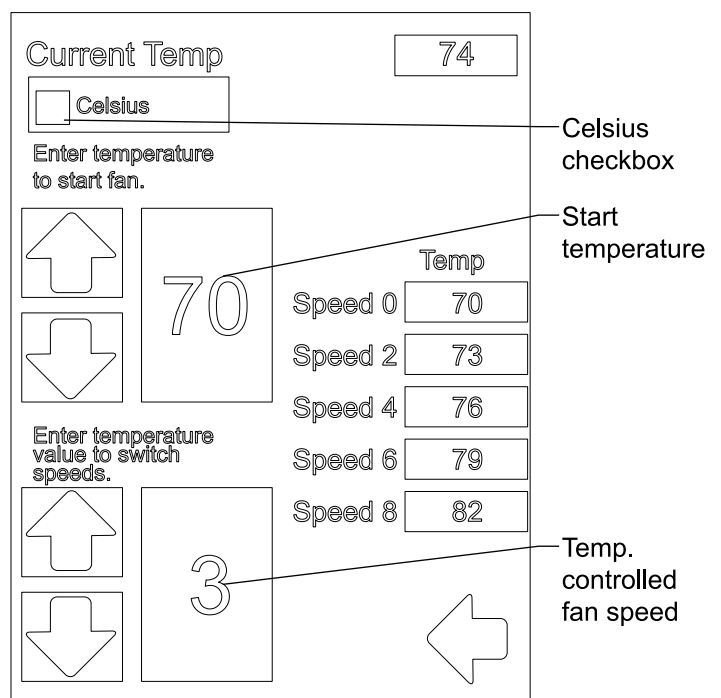

Celsius checkbox

Start temperature

Temp. controlled fan speed

OPERATING INSTRUCTIONS, continued

MULTI FAN CONTROL — OPTIONAL

MULTI FAN CONTROL SETUP

The multi fan control is a special program that allows user to control 2 to 4 fans with one remote. When the multi fan control touchscreen is installed, the initial setup screen will automatically display on the screen. Perform the following steps:

1. Select the quantity of fans to be controlled by the touchscreen. See Fig. 30.
2. Push SET button to confirm fan quantity to go to the verification screen. See Fig. 30.
3. Verify the fan numbers and press YES to return to the main screen or select NO to try again.

NOTE:

The initial view of the touchscreen control will prompt the installer to set and confirm the fan size for each individual fan. The Fan# is displayed on the top left corner. Use the UP/DOWN arrows to select the size of the fan and press the SET button. See Fig. 31. Ensure selected size matches the size specified on the label on the front of the VFD box. If it matches select the YES button on the following confirmation screen, if it differs, select the NO button and try again. Once the fan size is set, it will return to the main screen. Then click on the Fan# on the bottom of the screen to go to the next Fan number and set the fan size for next fan.

Fig. 30

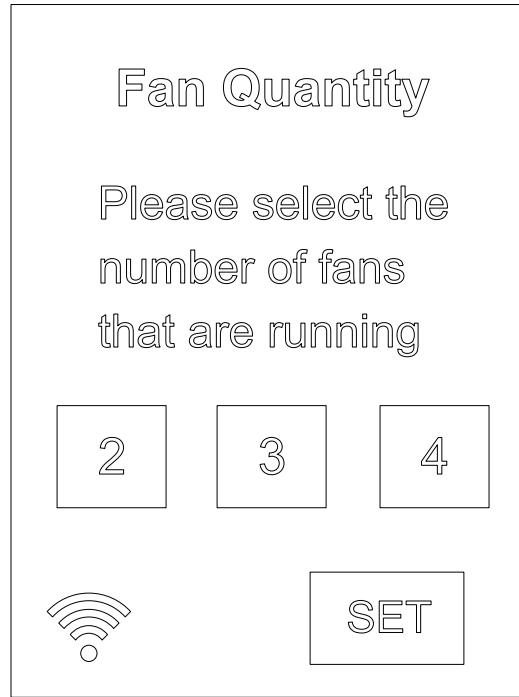
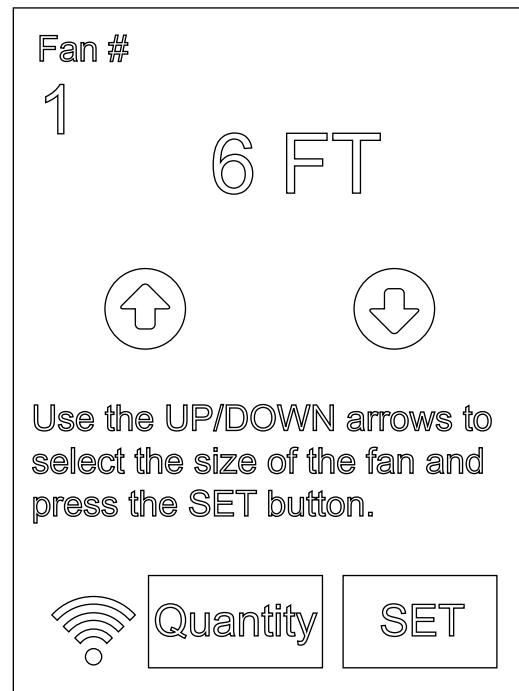

Fig. 31



OPERATING INSTRUCTIONS, continued

MULTI FAN CONTROL OPERATION

1. Press Fan# to select the fan that you would like to control.
2. The communication status on the bottom left corner will be Green if the fan is communicating.
3. Depending on the Fan Quantity that was set. The Fan# can be cycled through from 1 to the set fan quantity and then ALL which allows user to control all fans at one time.

Fig. 32

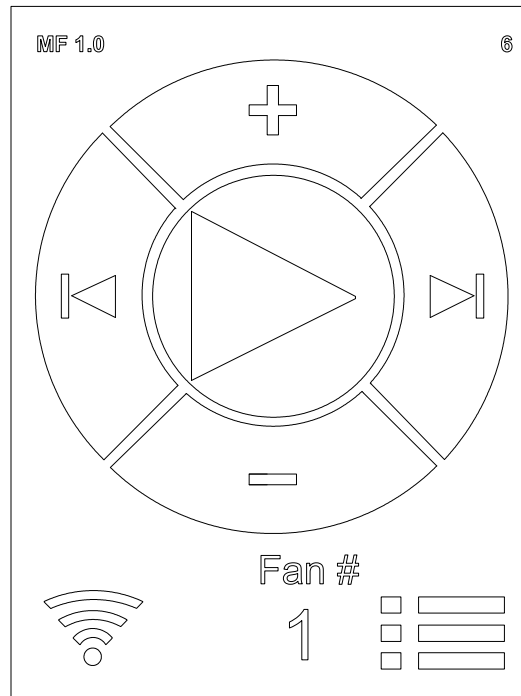

PLANNED MAINTENANCE

⚠ DANGER

Before service, inspection, or cleaning make certain that the power is disconnected and properly locked out.

⚠ WARNING

Before servicing the industrial fan, read and follow the Safety Practices on page 3 and the Operation section in this manual. Failure to do so could result in death or serious injury.



To ensure the continued proper operation of your industrial fan, perform the following planned maintenance procedures.

ANNUALLY

1. Inspect control panel for loose connections. Tighten as required.

2. Using dry air (shop air), blow out debris from fan motor cooling fan as required.
3. Inspect motor/gearbox for oil leaks. If present, consult distributor.
4. Inspect mounting hardware and tighten as required. Torque to 44–48 ft-lbs.
5. Inspect safety and guy wires for chaffing or wear. Ensure turnbuckle nut is secure. Replace as required.
6. Inspect guy wires for tension. Re-tighten as required.
7. Clean fan blades as required. Use a soft dry cloth. If necessary, use a mild detergent to clean surfaces. Do not use harsh cleansers.

Fig. 33

Legend	
Symbol	Description
	Cleaning (Location - Frequency)
	Visually Inspect (Replace Damaged Or Worn)
	Blow with Compressed Air (Location - Frequency)

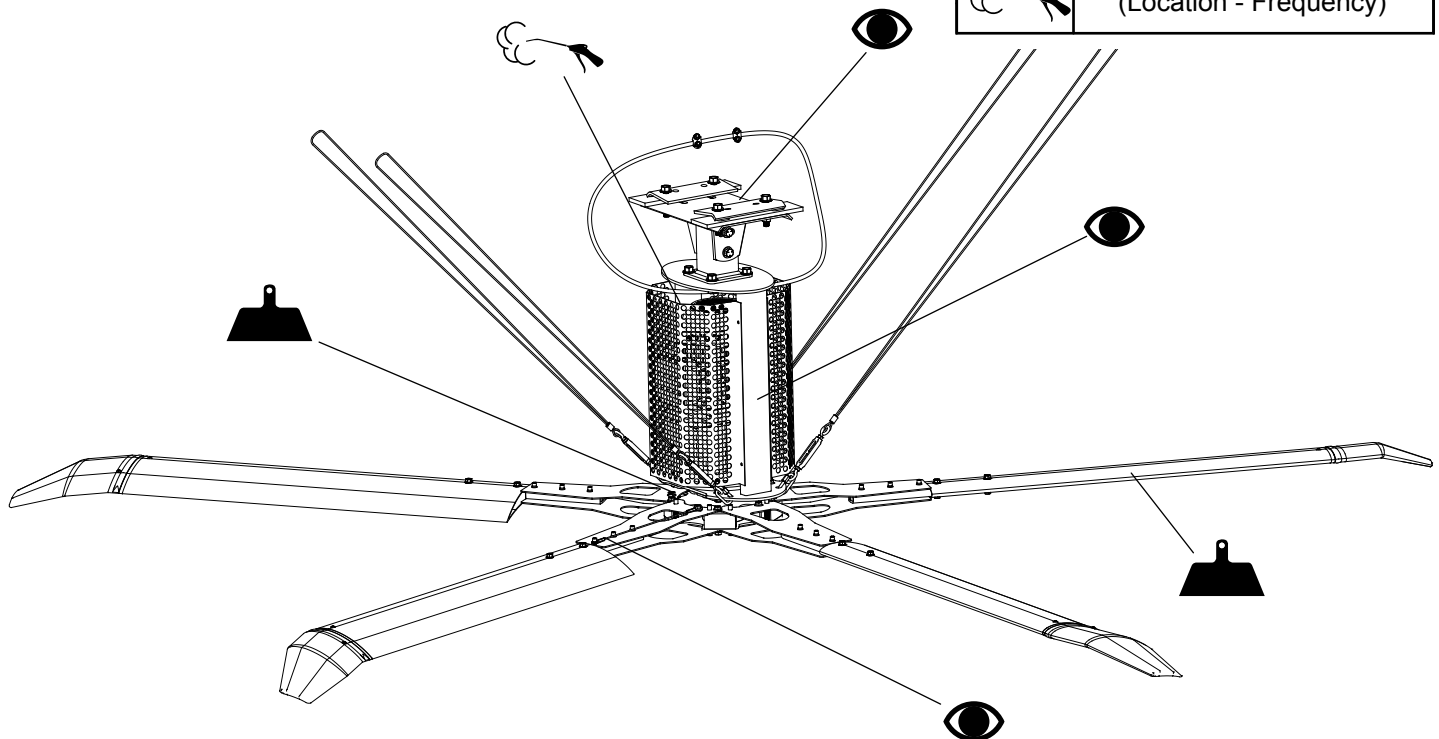

TROUBLESHOOTING GUIDE

⚠ WARNING

Before servicing the industrial fan, read and follow the Safety Practices on page 3 and the Operation section in this manual. Failure to do so could result in death or serious injury.

The functions of the industrial fan are controlled by a VFD (Variable Frequency Drive). Error codes are displayed on the touch screen Fault code screen. See table on page 29 for VFD diagnostics.

Use the Troubleshooting Guide if the industrial fan fails to perform properly. Find the condition that most closely matches your situation and make the recommended adjustments.

⚠ DANGER

Before service, inspection, or cleaning make certain that the power is disconnected and properly locked out. Before doing any electrical work, make certain the power is disconnected and properly locked or tagged off. Failure to do so may result in death or serious injury. All electrical troubleshooting and repair must be done by a qualified technician and meet all applicable codes. Do not route control wiring for any other device through the control box. Ensure that the voltage and phase of the incoming power agrees with the label located on top of the VFD box and fan. Be certain power is off when wiring to the control box. Failure to do so could result in electrical shock, death or serious injury.

Problem	Possible Cause	Solution
1. Fan does not operate.	<ul style="list-style-type: none"> a) No power to control panel. b) Primary fuse(s) blown. 	<ul style="list-style-type: none"> a) Ensure that the disconnect is in the ON position. Check for primary power at terminals b) Replace fuse(s)
2. Fan does not operate. Control panel has power.	<ul style="list-style-type: none"> a) Obstructions preventing movement. b) Remote not properly connected c) VFD faulted. d) Faulty fire jumper block. 	<ul style="list-style-type: none"> a) Check fan unit, ensure there are no obstructions preventing movement. b) Check connections between remote/ VFD. c) Check for VFD fault. Check fault code action - reset drive. (power OFF/power ON) d) Verify property DRIVE STATUS=64. If not, inspect jumper block on VFD box.
3. Fan operating, but turning in wrong direction.	<ul style="list-style-type: none"> a) Wire sequence. b) Intermittent connectivity inside remote control panel. 	<ul style="list-style-type: none"> a) Switch two phases of the output wiring from the VFD to the motor. b) Make sure the connections inside the remote control touchscreen are secure.
4. Fan operating, but generating high pitched whine.	<ul style="list-style-type: none"> a) Incorrect PWM frequency set. 	<ul style="list-style-type: none"> a) Consult authorized 4Front® distributor.
5. Fan operating, but shows excessive wobble.	<ul style="list-style-type: none"> a) Guy wires not tensioned properly. b) Winglet missing. 	<ul style="list-style-type: none"> a) Re-tension guy wires in accordance with the installation instructions on page 14. b) Replace winglet.
6. Fan generating a ticking noise, tick increases with speed.	<ul style="list-style-type: none"> a) Blades bolts not properly tightened. b) Fenner nut is loose. (item 21 on page 42) 	<ul style="list-style-type: none"> a) Loosen the the blade nuts. Support the blade level (horizontally) before torquing the bolts to 24-28 ft-lbs. b) Check interference between hub and frame, adjust and re-tighten the fenner nut as required

TROUBLESHOOTING GUIDE, continued

FAN DIAGNOSTIC TROUBLESHOOTING WITH OPTIONAL DIAGNOSTIC TOOL — 6015747

Fig. 34

NOTE:

Touch screen must be disconnected for diagnostic remote to function.

If the fan is not running, the current error code will be displayed on the screen. Consult the **VFD Fault Code** section of this manual to identify the issue.

If the fan is running the screen will be in **MONITOR** mode. **MONITOR** mode default display is VFD frequency output. It will also show motor current and motor voltage. Press the SET key to switch from one to another.

SERIAL NUMBER

1. Press the **MODE** key to switch from **MONITOR** mode to **PARAMETER** mode.
2. The display should be reading P.888. If it is not, turn the rotary dial until the display reads P.888.
3. Press the **SET** key. The display is now the first 3 digits of the serial number.
4. Press the **SET** key again and the display will show P.889. If it is not, turn the rotary dial until the display reads P.889.
5. Press the **SET** key. The display is now the last 4 digits of the serial number.
6. Press the **MODE** key to switch from **PARAMETER** mode to **MONITOR** mode. A red LED will illuminate under **MON** when in **MONITOR** mode.

ERROR HISTORY

1. Press the **MODE** key to switch from **MONITOR** mode to **ERROR** display. **E---** will be displayed.
2. Turn the rotary dial to scroll the errors. The error displayed with the . after the **E** is the most recent error.
3. Press the **MODE** key to switch from **PARAMETER** mode to **MONITOR** mode. A red LED will illuminate under **MON** when in **MONITOR** mode.

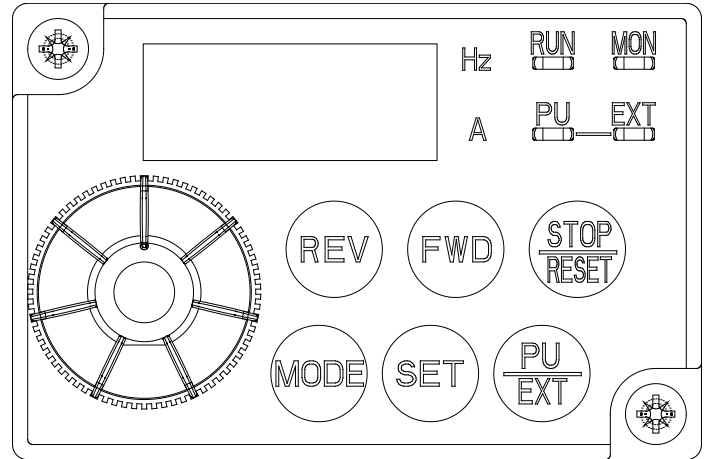

VARIABLE FREQUENCY DRIVE (VFD) – FAULT CODES

These codes will be shown on the VFD diagnostic device screen.

Fig. 35

Operation Panel Indication		Name	
Error message	E---	E---	Faults history
	HOLd	HOLD	Operation panel lock
	LOCd	LOCD	Password locked
	Er 1 to Er 4	Er1 to 4	Parameter write error
	Err.	Err.	Inverter reset
Warning	OL	OL	Stall prevention (overcurrent)
	oL	oL	Stall prevention (overvoltage)
	rb	RB	Regenerative brake pre-alarm
	rH	TH	Electronic thermal relay function pre-alarm
	PS	PS	PU stop
	MT	MT	Maintenance signal output
	UV	UV	Undervoltage
	SA	SA	Safety stop
Alarm	F _n	FN	Fan alarm
Fault	E.OC1	E.OC1	Overcurrent trip during acceleration
	E.OC2	E.OC2	Overcurrent trip during constant speed
	E.OC3	E.OC3	Overcurrent trip during deceleration or stop
	E.OV1	E.OV1	Regenerative overvoltage trip during acceleration
	E.OV2	E.OV2	Regenerative overvoltage trip during constant speed
	E.OV3	E.OV3	Regenerative overvoltage trip during deceleration or stop
	E.THT	E.THT	Inverter overload trip (electronic thermal O/L relay function)
	E.THM	E.THM	Motor overload trip (electronic thermal O/L relay function)
	E.FIN	E.FIN	Heatsink overheat

Operation Panel Indication		Name
E.ILF	E.ILF *	Input phase loss
E.OLT	E.OLT	Stall prevention stop
E. bE	E. BE	Brake transistor alarm detection
E. GF	E.GF	Output side earth (ground) fault overcurrent at start
E. LF	E.LF	Output phase loss
E.OHT	E.OHT	External thermal relay operation
E.PTC	E.PTC*	PTC thermistor operation
E. PE	E.PE	Parameter storage device fault
E.PUE	E.PUE	PU disconnection
E. RET	E.RET	Retry count excess
E. 5	E.5	CPU fault
E.CPU	E.CPU	
E.CDO	E.CDO*	Output current detection value exceeded
E.IOH	E.IOH *	Inrush current limit circuit fault
E.AIE	E.AIE *	Analog input fault
E.SAF	E.SAF *	Safety circuit fault

FIRE CONTROL SYSTEM FAN SHUTDOWN — OPTIONAL

This fan includes a fire alarm jumper for a building fire control systems option that allows the fan to be shut-down by the fire control system in case of a fire emergency.

Fig. 36

NOTE:

Ensure that the fire alarm jumper is in place or the building fire control system is connected and jumper removed.

1. The normally closed (NC) contacts must be dry contacts. They open in the event of an active fire alarm.
2. The fire control system fan shutdown option is not enabled when shipped. To enable the fire control system fan shutdown option, remove the jumper between enable (EN) and (24) and replace with a set of dry, normally closed contacts. See schematics for optional Fire Control Panels on pages 31 and 32.
3. To test the fire control system fan shutdown operation remove the wire from the NC contact at the building fire control panel. The fan should coast to a stop. See Fig. 36.

NOTICE

If the jumper is left installed the fan will not shut down due to fire control system contacts.

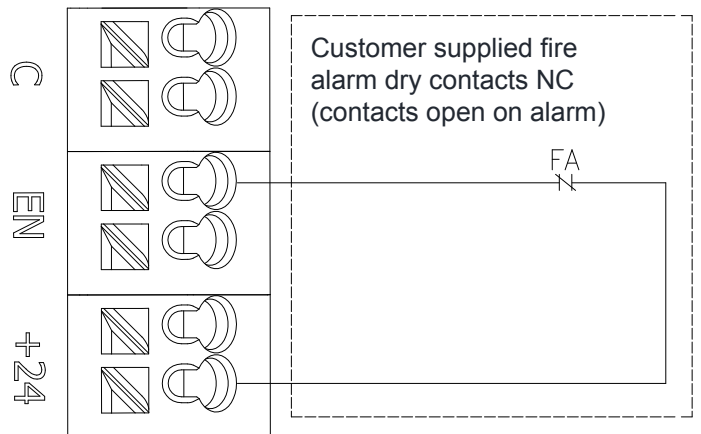
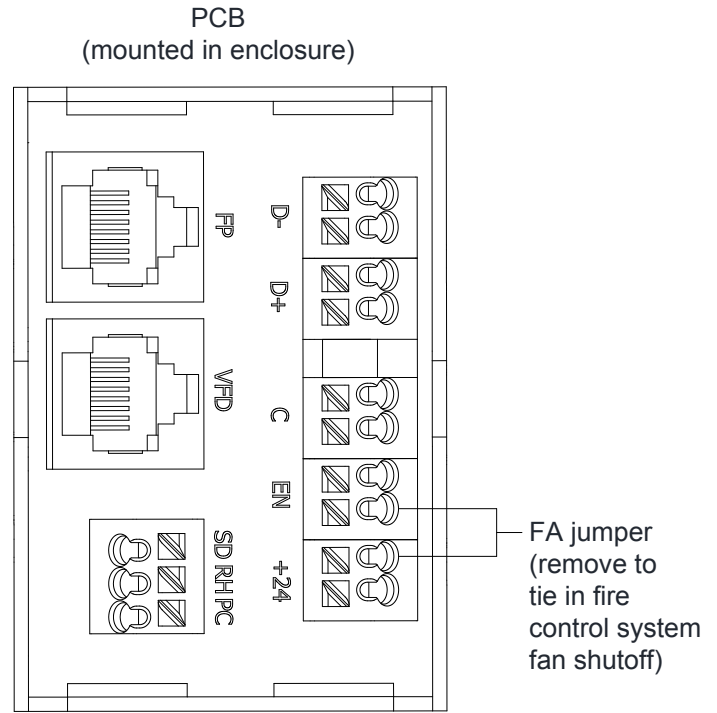

FIRE CONTROL SYSTEM FAN SHUTDOWN — OPTIONAL, continued

Fig. 37

FIRE CONTROL SYSTEM FAN SHUTDOWN PANEL — STANDARD INSTALLATION (6015291)

100–250V/1PH/60HZ

INCOMING SERVICE TO BE TERMINATED AT DISCONNECT
 CB/FU TO BE SUPPLIED BY OTHERS
 SUPPLY BCPD = CB/FU 5AMP MAX
 PANEL FLA = 0.6–0.3 AMPS
 SCCR = 5KA

TYPICAL INSTALLATION

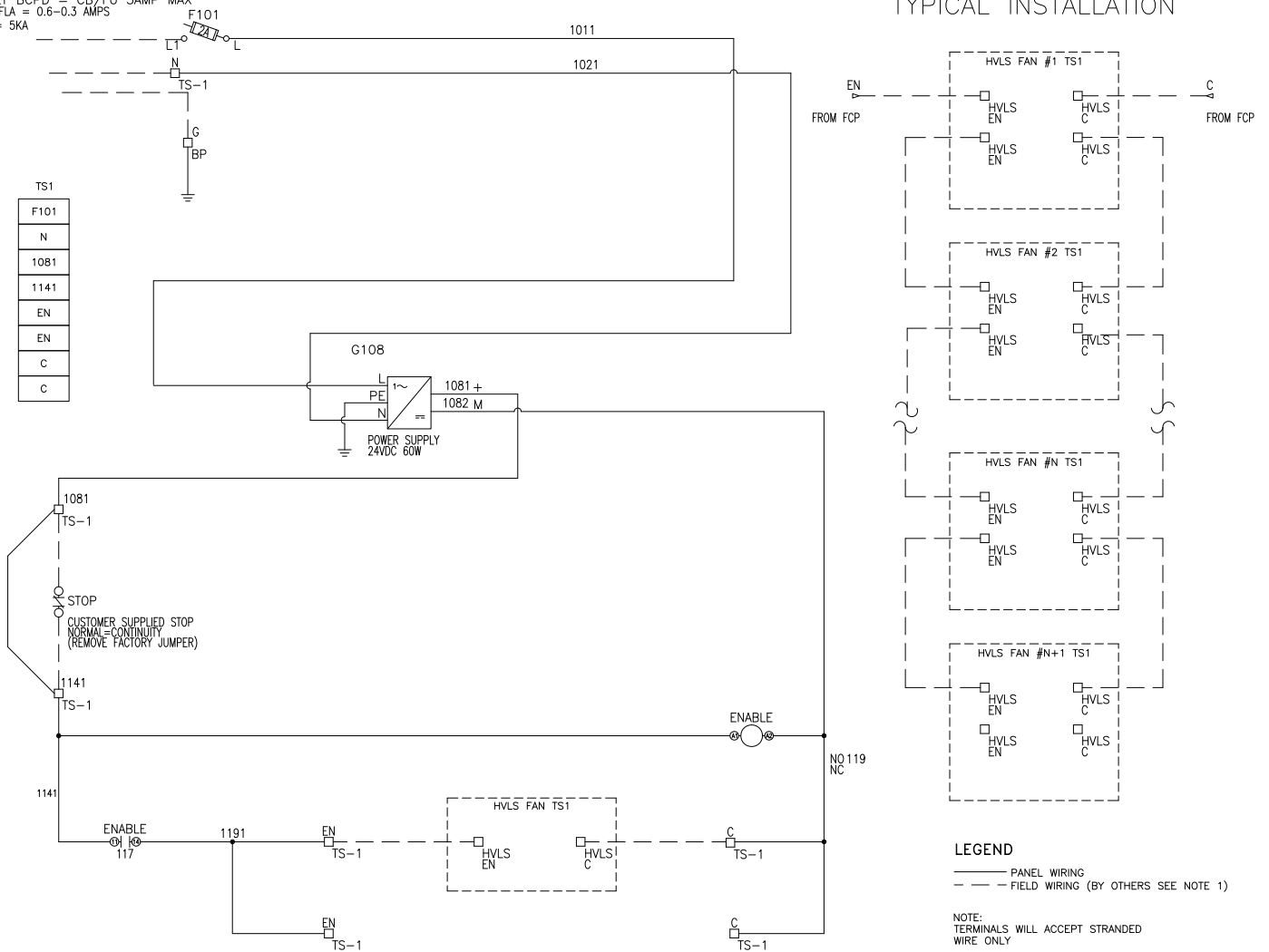

1. FIELD TERMINAL WIRING: 60 / 75 DEGREE WIRE, MIN 16AWG FOR SIGNAL WIRING, MIN 14AWG FOR INCOMING POWER, SEE CHART IN PANEL FOR TORQUE REQUIREMENTS
2. THE CONTACTS SHOULD BE CLOSED WHEN THERE IS NO ALARM (THE RELAY WILL BE ON WHEN NO ALARM).

⚠ DANGER

Before doing any electrical work, make certain the power is disconnected and properly locked or tagged off. Failure to do so may result in death or serious injury. All electrical troubleshooting and repair must be done by a qualified technician and meet all applicable codes. Do not route control wiring for any other device through this control box. Ensure that the voltage and phase of the incoming power agrees with the label located on top of the VFD box and fan. Be certain power is off when wiring to the control box. Failure to do so could result in electrical shock, death or serious injury.

LEGEND

— PANEL WIRING
 - - - FIELD WIRING (BY OTHERS SEE NOTE 1)

NOTE:
 TERMINALS WILL ACCEPT STRANDED WIRE ONLY

WIRE COLOR/GAUGE (NFPA) (unless otherwise specified)

208–600VAC: #14, BLK
 120VAC: #16, RED
 24VAC: #16, RED/BLK
 NEUTRAL: #16, WHT
 GROUND: GRN
 24VDC: #18, BLU
 24V COM (OVDC): #18, BLU/WHT
 12VAC/VDC: #18, VIO
 12V COM: #18, VIO/WHT
 DRY (UNPOWERED): #18, YLW

FIRE CONTROL SYSTEM FAN SHUTDOWN — OPTIONAL, continued

Fig. 38

FIRE CONTROL SYSTEM FAN SHUTDOWN PANEL — NETWORK INSTALLATION (6011644)

120V/1PH/60HZ

INCOMING SERVICE TO BE TERMINATED AT DISCONNECT
 CB/FU TO BE SUPPLIED BY OTHERS
 SUPPLY BCPD = CB/FU 15AMP MAX
 PANEL FLA = 1.2 AMPS
 SCCR = 5KA

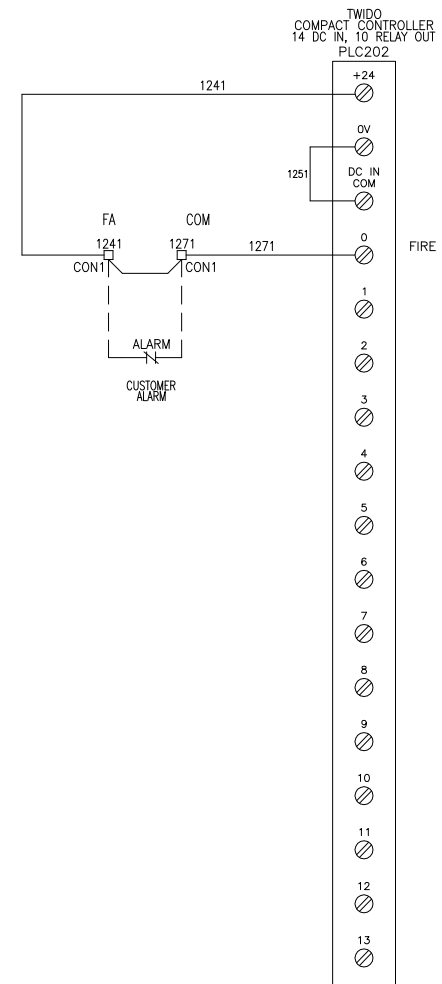
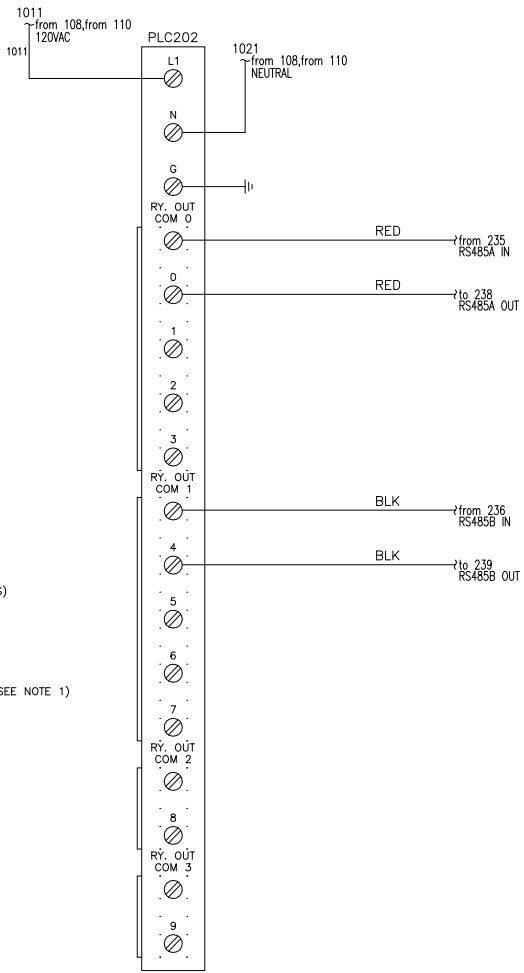
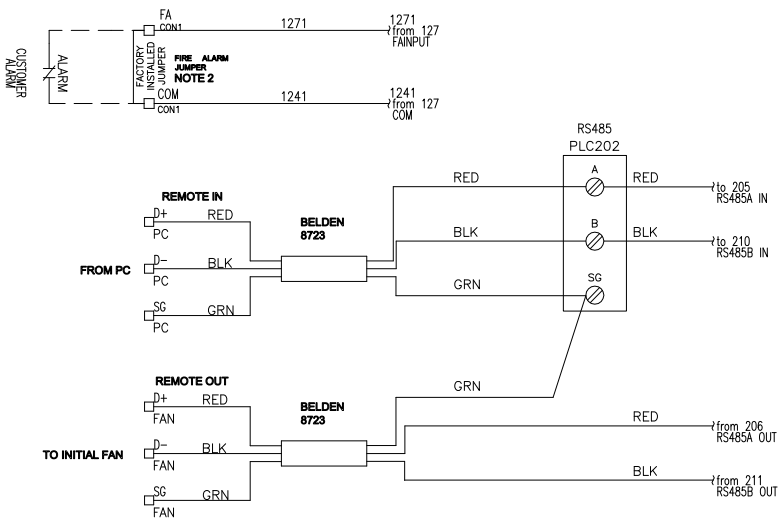
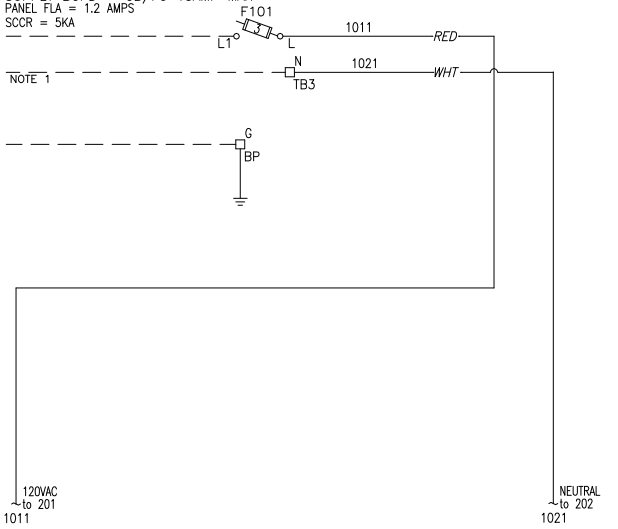

LEGEND
 ——— PANEL WIRING
 - - - FIELD WIRING (BY OTHERS)

LEGEND
 ——— PANEL WIRING
 - - - FIELD WIRING (BY OTHERS SEE NOTE 1)

NOTE:
 TERMINALS WILL ACCEPT STRANDED
 WIRE ONLY

WIRE COLOR/GAUGE (NEPA)

- (unless otherwise specified)
- 208-600VAC: #14, BLK
- 120VAC: #16, RED
- 24VAC: #16, RED/BLK
- NEUTRAL: #16, WHT
- GROUND: GRN
- 24VDC: #18, BLU
- 24V COM (OVDC): #18, BLU/WHT
- 12VAC/VDC, #18, VIO
- 12V COM: #18, VIO/WHT
- DRY (UNPOWERED): #18, YLW

ELECTRICAL SCHEMATICS, continued

Fig. 39

1PH WIRING DETAILS

INCOMING SERVICE TERMINATED AT DISCONNECT
 SUPPLY BCPD = SEE CHART
 PANEL FLA = SEE CHART
 SCCR 5KA

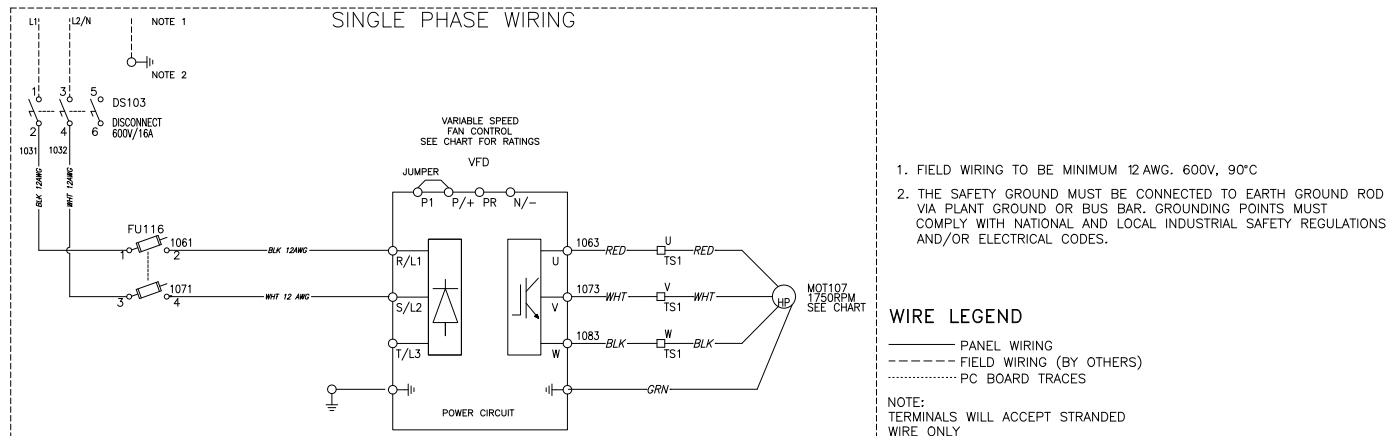

SIZING CHART			
	6014870	6014871	6014872
VOLTAGE	120/1PH/50/60HZ	230/1PH/50/60HZ	230/1PH/50/60HZ
FLA	10.2A	8A	14.3
FUSE	KTKR15	KTKR12	KTKR20
MOTOR	1HP, 2.6FLA @ 265V/60HZ	1HP, 2.6FLA @ 265V/60HZ	2HP, 5.1FLA @ 265V/60HZ
LINE REACTOR	N/A	N/A	N/A
VFD	100 120/1PH 1HP/.75KW/4.2A	200 230/1PH 1HP/.75KW/4.2A	200 230/1PH 2HP/1.5KW/7.0A
O/L	3.4	3.4	6.8

⚠ DANGER

Before doing any electrical work, make certain the power is disconnected and properly locked or tagged off. Failure to do so may result in death or serious injury. All electrical troubleshooting and repair must be done by a qualified technician and meet all applicable codes. Do not route control wiring for any other device through this control box. Ensure that the voltage and phase of the incoming power agrees with the label located on top of the VFD box and fan. Be certain power is off when wiring to the control box. Failure to do so could result in electrical shock, death or serious injury.

ELECTRICAL SCHEMATICS, continued

Fig. 40

3PH WIRING DETAILS

INCOMING SERVICE TERMINATED AT DISCONNECT
 SUPPLY BCPD = SEE CHART
 PANEL FLA = SEE CHART
 SCCR 5KA

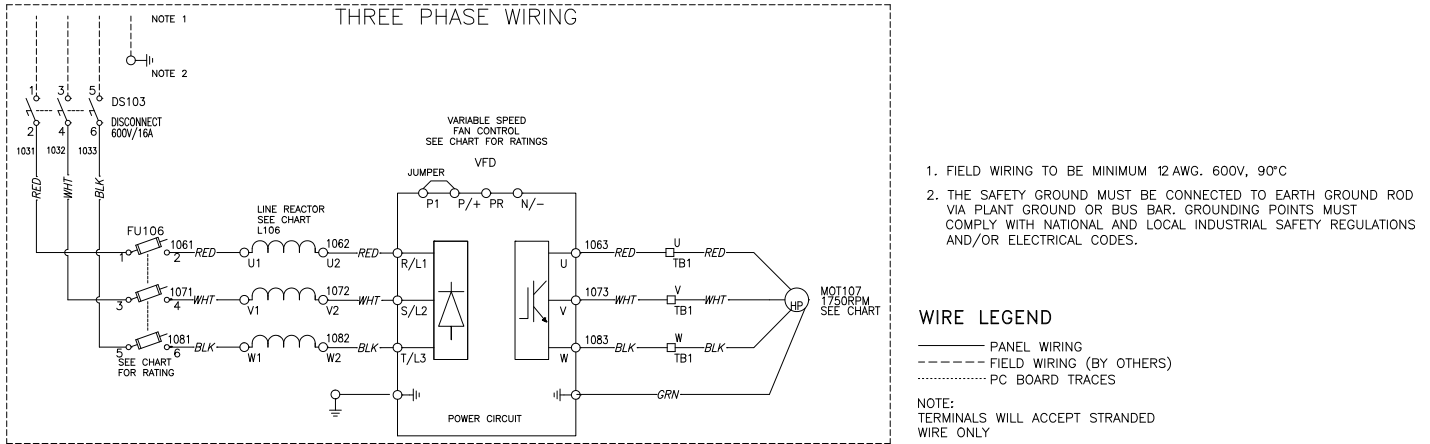

SIZING CHART				
	6014873	6014874	6014875	6014876
VOLTAGE	230/3PH/50/60HZ	230/3PH/50/60HZ	460/3PH/50/60HZ	460/3PH/50/60HZ
FLA	4.2A	6A	2.5A	4.5A
FUSE	KTKR5	KTKR10	KTKR3	KTKR5
MOTOR	1HP, 2.6FLA @ 265V/60HZ	2HP, 5.1FLA @ 265V/60HZ	1HP, 1.6FLA @ 460V/60HZ	2HP, 3.0FLA @ 460V/60HZ
LINE REACTOR	6010719	6010720	6010722	6010718
VFD	200 230/3PH 1HP/.75KW/4.2A	200 230/3PH 2HP/1.5KW/7.0A	360 480/3PH 1HP/.75KW/2.2A	360 480/3PH 2HP/1.5KW/3.6A
O/L	3.4	6.8	2	3.4

ELECTRICAL SCHEMATICS, continued

Fig. 41

VARIABLE FREQUENCY DRIVE I/O

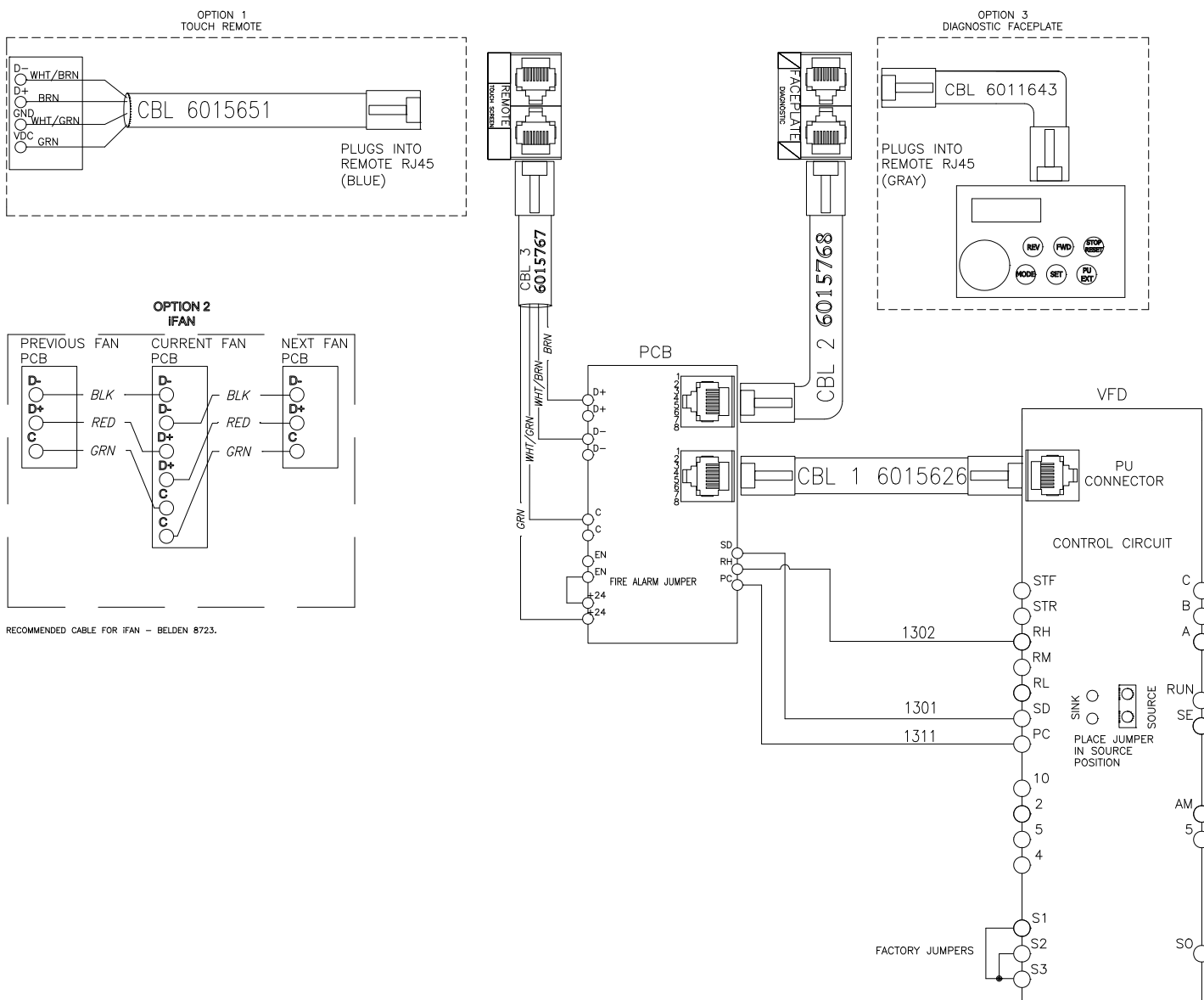

TEMP CONTROL WIRING DETAILS — OPTIONAL

Fig. 42

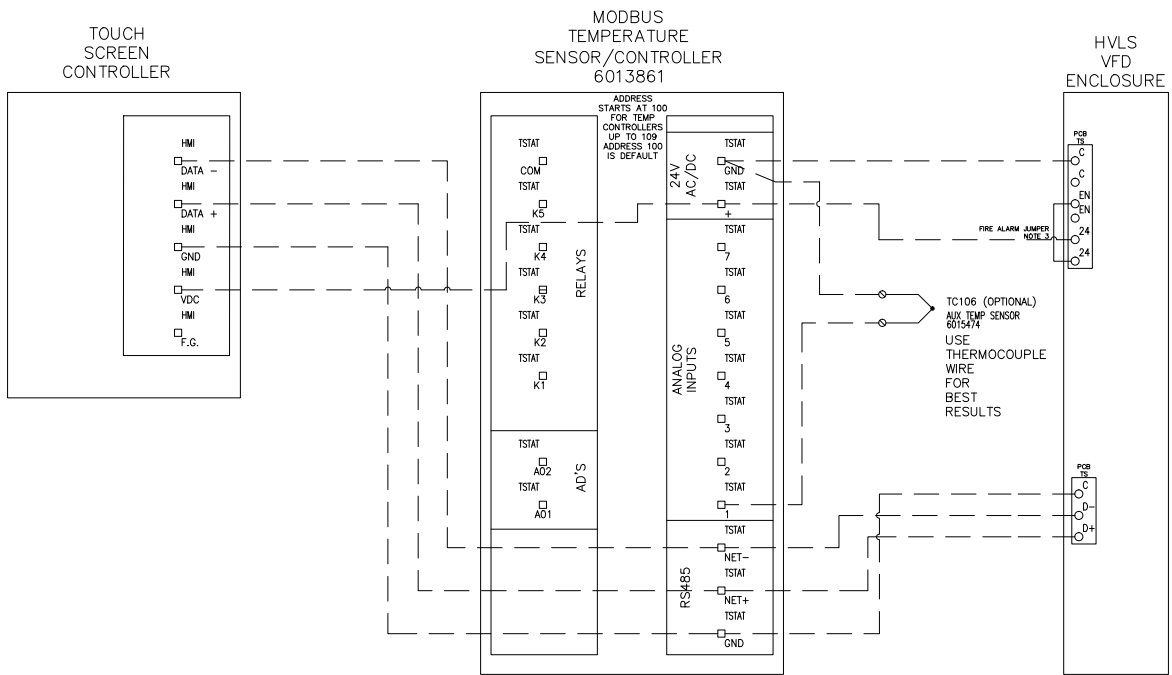

MULTI FAN WIRING DETAILS — OPTIONAL

Fig. 43

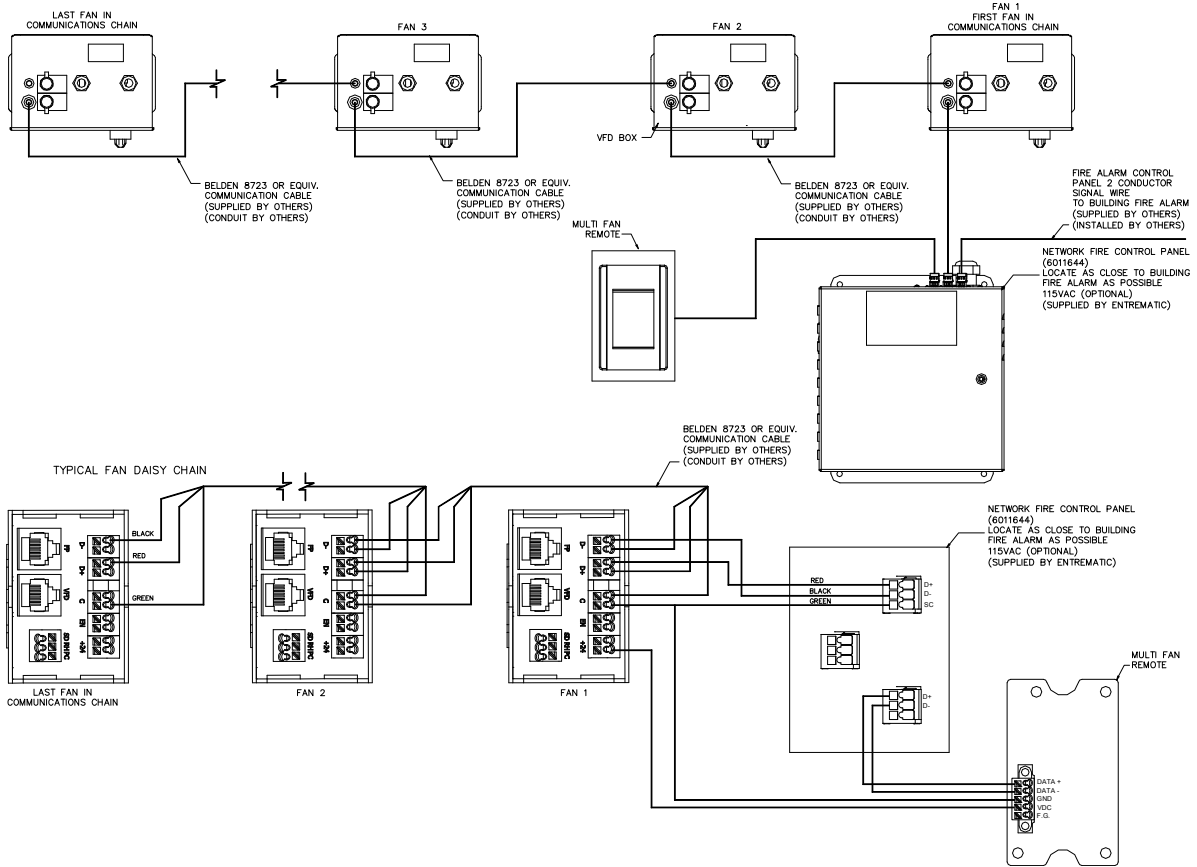

550-600V SUPPLY WIRING DETAILS — OPTIONAL

To connect 480V fan to 550-600V building supply, a step down transformer assembly (6017277) must be installed between power supply and the VFD enclosure. Wiring (by others) must be 600V rated 14 ga. All wiring must be installed in accordance with any national, state or local code requirements.

NOTICE

The transformer assembly is rated for one single fan load only. Each fan must have its own step down transformer assembly (6017277).

1. Locate and mount the step down transformer (6017277) outside the blade arc and near the VFD enclosure.
2. Route supply power from the building source to the step down transformer.
3. Follow VFD installation instructions on page 15 using power from step down transformer (6017277) as the power source.

⚠ DANGER

Before doing any electrical work, make certain the power is disconnected and properly locked or tagged off. Failure to do so may result in death or serious injury. All electrical troubleshooting and repair must be done by a qualified technician and meet all applicable codes. Do not route control wiring for any other device through this enclosure. Ensure that the voltage and phase of the incoming power agrees with the label located on top of the VFD box and fan. Be certain power is off when wiring to the control box. Failure to do so could result in electrical shock, death or serious injury.

Fig. 44

575-600V/3 ϕ /60HZ

INCOMING SERVICE TERMINATED AT DISCONNECT
BCPD 15A (CB/FU)
PANEL FLA 6
SCCR 5KA

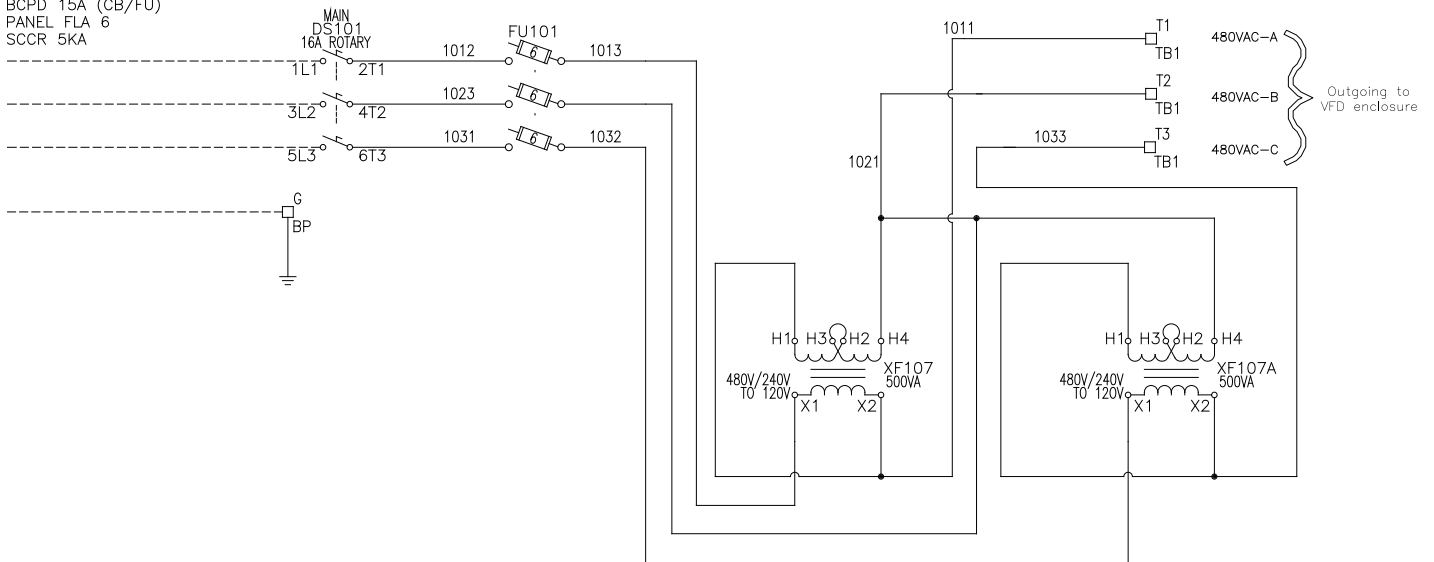

PARTS LIST — FAN

Fig. 45

⚠ WARNING

To ensure proper function, durability and safety of the product, only replacement parts that do not interfere with the safe, normal operation of the product must be used. Incorporation of replacement parts or modifications that weaken the structural integrity of the product, or in any way alter the product from its normal working condition at the time of purchase from 4Front® Engineered Solutions could result in product malfunction, breakdown, premature wear, death or serious injury.

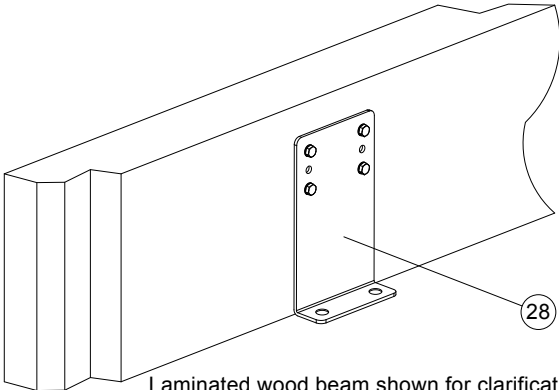

Laminated wood beam shown for clarification

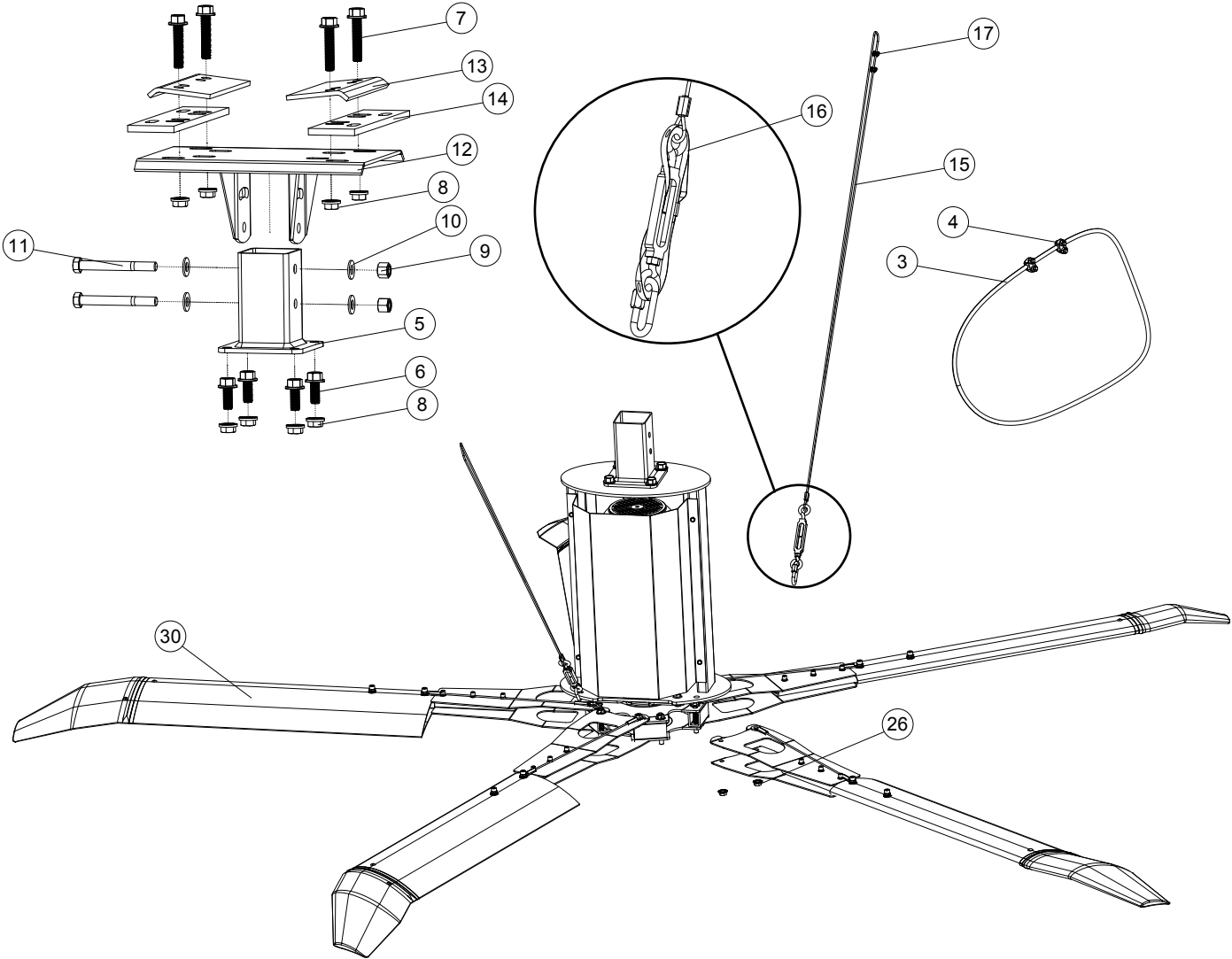

PARTS LIST — FAN, continued

Fig. 46

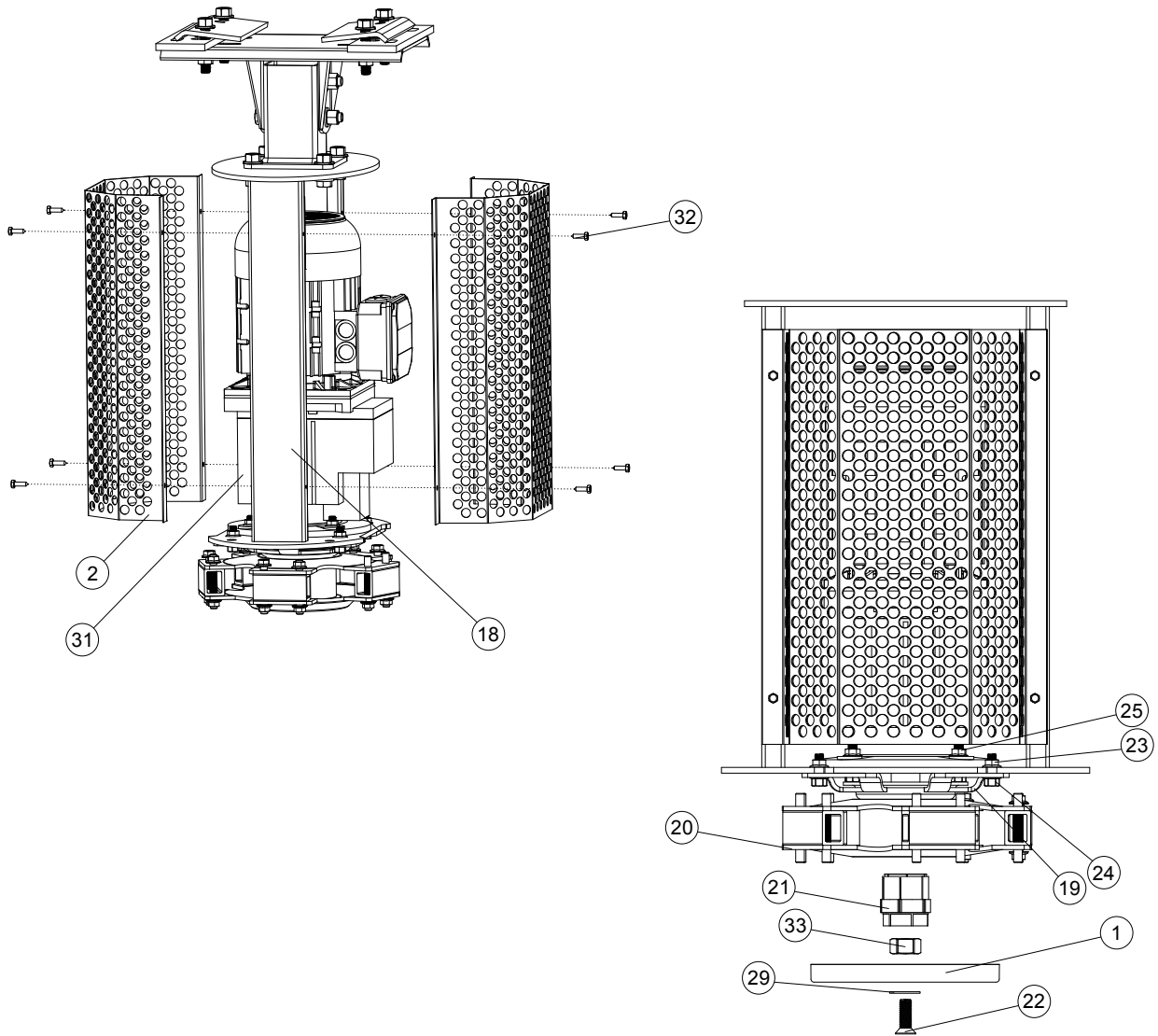

PARTS LIST — FAN, continued

Item	Quantity	Description	Part Number
1	1	KELLEY BRANDED HUB CAP SERCO BRANDED HUB CAP	6015112 6015113
2	2	SILVER MOTOR COVER BLACK MOTOR COVER	6015806 6015820
3	1	SAFETY CABLE — 170" LONG - 6", 1', 2' EXT SAFETY CABLE — 242" LONG - 3', 4', 5' EXT SAFETY CABLE — 314" LONG - 6', 7', 8' EXT SAFETY CABLE — 386" LONG - 9', 10', 11', 12' EXT	6014884 6014887 6014890 6015864
4	2	CABLECLAMP 1/4" PLD	441103
5	1	HVLS EXT MNT 12" HVLS EXT MNT 24" HVLS EXT MNT 36" HVLS EXT MNT 48" HVLS EXT MNT 60" HVLS EXT MNT 72" HVLS EXT MNT 84" HVLS EXT MNT 96" HVLS EXT MNT 108" HVLS EXT MNT 120" HVLS EXT MNT 132" HVLS EXT MNT 144"	6015865 6015866 6015867 6015868 6015869 6015870 6015871 6015872 6015873 6015874 6015875 6015876
6	4	1/2-13UNC X 1 1/4" LG SER FLG	6015851
7	4	1/2-13UNC X 2 1/2" LG SER FLG	6015852
8	8	NUT, HEX FLG, SER, 1/2-13UNC	6015853
9	2	LN 1/2 NYLON INSERT LOCKNUT	214505
10	4	PW - 1/2" ID - SAE	234260
11	2	HHB 1/2-13UNC X 4 1/2 LG, GRD5	6013220
12	2	PIVOT, HANGER BRACKET MOUNT	6016400
13	2	PLATE, HANGER BRACKET CLAMP	6014953
14	2	PLATE, CLAMP SPACER	6014954
15	4	GUY WIRE KIT - 6FT, 7FT, 8FT EXT GUY WIRE KIT - 9FT, 10FT EXT	6015676 6015678
16	4	SECONDARY STRAP TIE, BALL LOCK	6015265
17	8	1/8" WIRE CABLE CLAMP	6010900
18	1	HVLS FAN FRAME	6014980
19	2	SAFETY BRACKET	6015056

NOTE:

For corrosion resistant or explosion proof fans, consult factory for parts.

PARTS LIST — FAN, continued

Item	Quantity	Description	Part Number
20	1	HUB ASSEMBLY	6015020
21	1	FENNER NUT — KEYLESS BUSHING - 1 1/4" I.D. X 2" O.D.	6013286
22	2	HUB COVER BOLT LEFT HAND THREAD	6015097
23	8	3/8-16UNC HEX SERRATED FLANGE NUT	6015118
24	4	3/8-16UNC X 1.0 LG SER FLG HEX CAP SCREW	6015679
25	4	3/8-16UNC X 1 1/4 LG SER FLG HEX CAP SCREW	6009379
26	20	NUT, HEX FLG, SER, 3/8-16UNF	6015118
27	1	CORD GRIP, .354-.709" PG21 — NOT SHOWN	6010709
28	1	LAMINATED WOOD BEAM BRACKET ASSEMBLY — OPTIONAL	6014915
29	1	WASHER, 2" OD - 1/2" ID THICK SERIES	6017018
30	5	BLADE ASSY, 6FT, Q-5X M3, SILVER BLADE ASSY, 8FT, Q-5X M3, SILVER BLADE ASSY, 10FT, Q-5X M3, SILVER BLADE ASSY, 12FT, Q-5X M3, SILVER BLADE ASSY, 14FT, Q-5X M3, SILVER BLADE ASSY, 16FT, Q-5X M3, SILVER BLADE ASSY, 18FT, Q-5X M3, SILVER BLADE ASSY, 20FT, Q-5X M3, SILVER BLADE ASSY, 22FT, Q-5X M3, SILVER BLADE ASSY, 24FT, Q-5X M3, SILVER BLADE ASSY, 6FT, Q-5X M3, BLACK BLADE ASSY, 8FT, Q-5X M3, BLACK BLADE ASSY, 10FT, Q-5X M3, BLACK BLADE ASSY, 12FT, Q-5X M3, BLACK BLADE ASSY, 14FT, Q-5X M3, BLACK BLADE ASSY, 16FT, Q-5X M3, BLACK BLADE ASSY, 18FT, Q-5X M3, BLACK BLADE ASSY, 20FT, Q-5X M3, BLACK BLADE ASSY, 22FT, Q-5X M3, BLACK BLADE ASSY, 24FT, Q-5X M3, BLACK	6015021 6015022 6015023 6015024 6015025 6015026 6015027 6015028 6015848 6015029 6015821 6015822 6015823 6015824 6015825 6015826 6015827 6015828 6015847 6015829
31	1	GEAR MOTOR, 1HP, 480/3, 8.16 — 6' AND 8' MODELS GEAR MOTOR, 1HP, 480/3, 14.28 — 10' AND 12' MODELS GEAR MOTOR, 1HP, 480/3, 20.04 — 14' AND 16' MODELS GEAR MOTOR, 1HP, 480/3, 24.93 — 18' AND 20' MODELS GEAR MOTOR, 2HP, 480/3, 24.93 — 24' MODELS	6015074 6015079 6015084 6015089 6015092
32	8	FAN COVER FASTENERS	215702
33	1	NUT, 3/4-10 UNC	000043

PARTS LIST — VFD BOX

Fig. 47

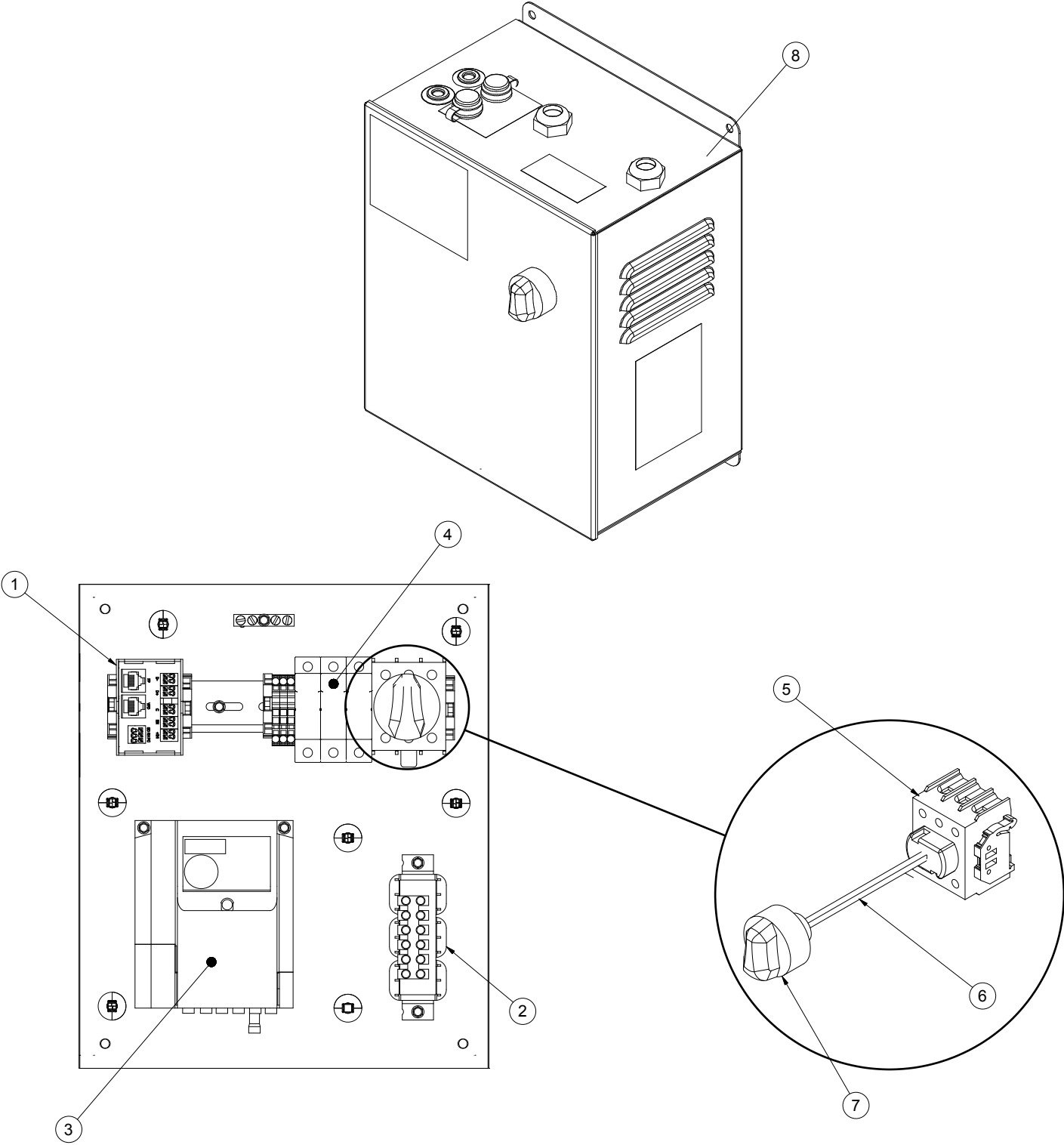

PARTS LIST — VFD BOX, continued

6014870 — 120V/1PH/1HP

Item	Quantity	Part Description	Part Number
1	1	INTERFACE, HVLS DIN RAIL MOUNT PCB	6015547
2	—	—	—
3	1	MISTUBISHI VFD, 120V, 1PH, 1HP	6014902
4	2	FUSE 15A, 600V, KTK-R-15	6011800
5	1	ROTARY DISCONNECT	6015597
6	1	DISCONNECT SHAFT 150MM	6015599
7	1	DISCONNECT HANDLE	6015598
8	1	VFD CONTROL BOX ASSY	6014870

6014871 — 230V/1PH/1HP

Item	Quantity	Part Description	Part Number
1	1	INTERFACE, HVLS DIN RAIL MOUNT PCB	6015547
2	—	—	—
3	1	MISTUBISHI VFD, 230V, 1PH, 2HP	6014904
4	2	FUSE 12A, 600V, KTK-R-12	6011799
5	1	ROTARY DISCONNECT	6015597
6	1	DISCONNECT SHAFT 150MM	6015599
7	1	DISCONNECT HANDLE	6015598
8	1	VFD CONTROL BOX ASSY	6014871

6014872 — 230V/1PH/2HP

Item	Quantity	Part Description	Part Number
1	1	INTERFACE, HVLS DIN RAIL MOUNT PCB	6015547
2	—	—	—
3	1	MISTUBISHI VFD, 230V, 1PH, 2HP	6014904
4	2	FUSE 20A, 600V, KTK-R-20	6011801
5	1	ROTARY DISCONNECT	6015597
6	1	DISCONNECT SHAFT 150MM	6015599
7	1	DISCONNECT HANDLE	6015598
8	1	VFD CONTROL BOX ASSY	6014872

PARTS LIST — VFD BOX, continued

6014873 — 230V/3PH/1HP

Item	Quantity	Part Description	Part Number
1	1	INTERFACE, HVLS DIN RAIL MOUNT PCB	6015547
2	1	LINE REACTOR, 600V, 4.8A	6010719
3	1	MISTUBISHI VFD, 230V, 3PH, 2HP	6014907
4	3	FUSE 5A, 600V, KTK-R-5	6011797
5	1	ROTARY DISCONNECT	6015597
6	1	DISCONNECT SHAFT 150MM	6015599
7	1	DISCONNECT HANDLE	6015598
8	1	VFD CONTROL BOX ASSY	6014873

6014874 — 230V/3PH/2HP

Item	Quantity	Part Description	Part Number
1	1	INTERFACE, HVLS DIN RAIL MOUNT PCB	6015547
2	1	LINE REACTOR, 600V, 7.6A	6010720
3	1	MISTUBISHI VFD, 230V, 3PH, 2HP	6014907
4	3	FUSE 10A, 600V, KTK-R-10	6014015
5	1	ROTARY DISCONNECT	6015597
6	1	DISCONNECT SHAFT 150MM	6015599
7	1	DISCONNECT HANDLE	6015598
8	1	VFD CONTROL BOX ASSY	6014874

6014875 — 460V/3PH/1HP

Item	Quantity	Part Description	Part Number
1	1	INTERFACE, HVLS DIN RAIL MOUNT PCB	6015547
2	1	LINE REACTOR, 600V, 2.1A	6010722
3	1	MISTUBISHI VFD, 480V, 3PH, 2HP	6014909
4	3	FUSE 3A, 600V, KTK-R-3	6011795
5	1	ROTARY DISCONNECT	6015597
6	1	DISCONNECT SHAFT 150MM	6015599
7	1	DISCONNECT HANDLE	6015598
8	1	VFD CONTROL BOX ASSY	6014875

PARTS LIST — VFD BOX, continued

6014876 — 460V/3PH/2HP

Item	Quantity	Part Description	Part Number
1	1	INTERFACE, HVLS DIN RAIL MOUNT PCB	6015547
2	1	LINE REACTOR, 600V, 3.4A	6010718
3	1	MISTUBISHI VFD, 480V, 3PH, 2HP	6014909
4	3	FUSE 5A, 600V, KTK-R-5	6011797
5	1	ROTARY DISCONNECT	6015597
6	1	DISCONNECT SHAFT 150MM	6015599
7	1	DISCONNECT HANDLE	6015598
8	1	VFD CONTROL BOX ASSY	6014876

PARTS LIST — REMOTE CONTROL PANEL, continued

Fig. 48

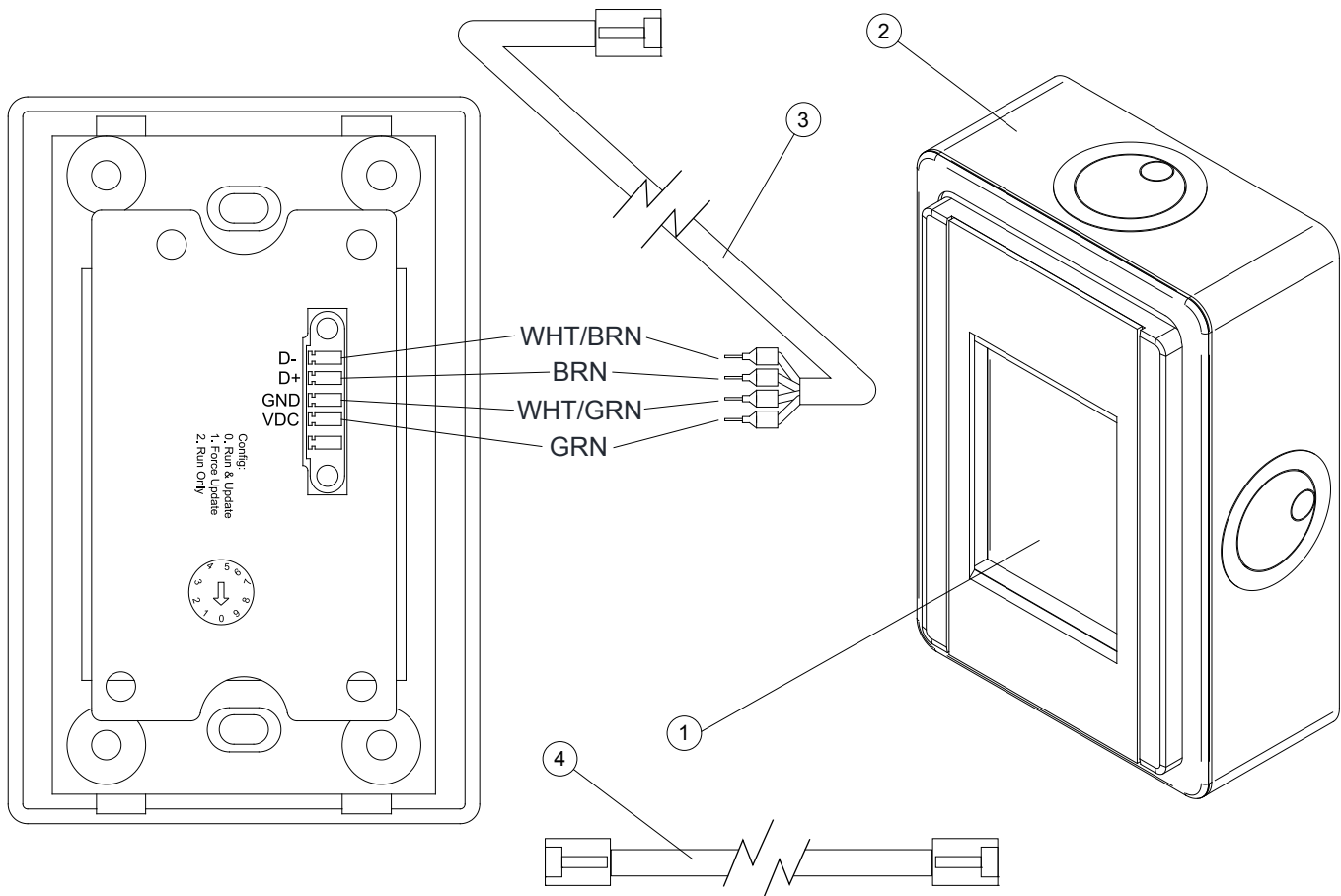

Item	Quantity	Part Description	Part Number
1	1	TOUCH SCREEN CONTROLLER, KELLEY TOUCH SCREEN CONTROLLER, SERCO TOUCH SCREEN CONTROLLER W/ TEMP CONTROL, KELLEY TOUCH SCREEN CONTROLLER W/ TEMP CONTROL, SERCO TOUCH SCREEN CONTROLLER — MULTI FAN REMOTE, KELLEY TOUCH SCREEN CONTROLLER — MULTI FAN REMOTE, SERCO	6015758 6015759 6016570 6016571 6016943 6016944
2	1	J-BOX , PLASTIC, IVORY	6015648
3	1	CABLE CAT5, 100' W/ FERRULE (BLUE)	6015651
4	1	CABLE CAT5 (GRAY)	6011643

PARTS LIST — TEMP CONTROL (OPTIONAL)

Fig. 49

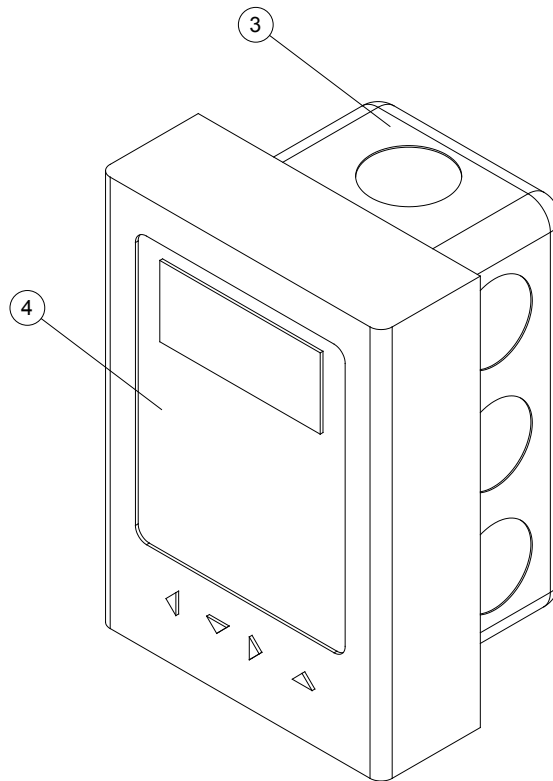

Item	Quantity	Part Description	Part Number
1	1	TEMP CONTROL ASSEMBLY	6013862
2	2	PHILIPS HEAD SCREW (NOT SHOWN)	6013543
3	1	4X2 STEEL J-BOX	6013415
4	1	MODBUS TEMP/IO CONTROL	6013861

WARRANTY

THIS LIMITED WARRANTY IS 4FRONT'S SOLE AND EXCLUSIVE WARRANTY WITH RESPECT TO THE HVLS FAN AND IS IN LIEU OF ANY OTHER GUARANTEES OR WARRANTIES, EXPRESS OR IMPLIED. THIS LIMITED WARRANTY APPLIES ONLY TO THE ORIGINAL PURCHASER OF THE HVLS FAN AND CANNOT BE TRANSFERRED.

4FRONT warrants that this HVLS FAN will be free from flaws in material and workmanship under normal use for a period of one (1) year from the earlier of 1) 60 days after the date of initial shipment by 4FRONT, or 2) the date of installation of the HVLS FAN by the original purchaser, provided that the owner maintains and operates the HVLS FAN in accordance with this User's Manual.

In the event that this HVLS FAN proves deficient in material or workmanship within the applicable Limited Warranty period, owner shall so notify 4FRONT, and 4 Front will, at its option:

1. Replace the HVLS FAN, or the deficient portion(s) thereof, without charge to the owner; or
2. Alter or repair the HVLS FAN, on site or elsewhere, without charge to the owner.

In addition, 4FRONT warrants the HVLS FAN for an additional two (2) years for replacement parts only and an additional nine (9) years for parts only on a pro-rated basis.

Exclusions to the limited warranty: Blades, hub assembly and frame are warranted for the useful life of the product to a maximum of 12 years from either; 1) 60 days after the date of initial shipment by 4FRONT, or 2) the date of installation of the HVLS FAN by the original purchaser, provided that the owner maintains and operates the HVLS FAN in accordance with this User's Manual.

This Limited Warranty does not cover any failure caused by improper installation, abuse, improper operation, negligence, or failure to maintain and adjust the HVLS FAN properly. Parts requiring replacement due to damage resulting from vehicle impact, abuse, or improper operation are not covered by this warranty. 4FRONT DISCLAIMS ANY RESPONSIBILITY OR LIABILITY FOR ANY LOSS OR DAMAGE OF ANY KIND (INCLUDING WITHOUT LIMITATION, DIRECT, INDIRECT, CONSEQUENTIAL OR PUNITIVE DAMAGES, OR LOST PROFITS OR LOST PRODUCTION) arising out of or related to the use, installation or maintenance of the HVLS FAN (including premature product wear, product failure, property damage or bodily injury resulting from use of unauthorized replacement parts or modification of the HVLS FAN). 4FRONT's sole obligation with regard to a HVLS FAN that is claimed to be deficient in material or workmanship shall be as set forth in this Limited Warranty. This Limited Warranty will be null and void if the original purchaser does not notify 4FRONT's warranty department within ninety (90) days after the product deficiency is discovered. .

THERE ARE NO WARRANTIES, EXPRESS OR IMPLIED, WHICH EXTEND BEYOND THE DESCRIPTION ON THE FACE HEREOF, INCLUDING, BUT NOT LIMITED TO, A WARRANTY OF MERCHANTABILITY OR OF FITNESS FOR A PARTICULAR PURPOSE, ALL OF WHICH 4FRONT HEREBY DISCLAIMS.

Please direct questions about your fan to your local distributor.

Your local distributor is:

Corporate Office:

1612 Hutton Dr. Suite 140

Carrollton, TX. 75006

Tel. (972) 466-0707

Fax (972) 323-2661

4Front Engineered Solutions®